

# WORKBOOK. MATH 06. BASIC CONCEPTS OF MATHEMATICS II.

DEPARTMENT OF MATHEMATICS AND COMPUTER SCIENCE

Contributors: N. Apostolakis, M. Bates, Q. Fang, S. Forman, Y. Hu, U. Iyer, A. Kheyfits, R. Kossak, A. McInerney, and Ph. Rothmaler

Department of Mathematics and Computer Science, CP 315, Bronx Community College, University Avenue and West 181 Street, Bronx, NY 10453.

Version 4, Summer 2016

## CONTENTS

|   |     |
|---|-----|
| 1. Roots and Radicals                                     | 3   |
| 2. Operations on radical expressions                      | 10  |
| 3. Solving Radical equations                              | 13  |
| 4. Rational exponents                                     | 14  |
| 5. Complex Numbers  | 17  |
| 6. Solving Quadratic equations                            | 21  |
| 7. Introduction to Parabolas                              | 32  |
| 8. Simplifying Rational Expressions                       | 37  |
| 9. Multiplication and Division of Rational Expressions    | 63  |
| 10. Addition and Subtraction of rational expressions      | 65  |
| 11. Complex Fractions                                     | 72  |
| 12. Solving rational equations                            | 74  |
| 13. Exponential functions                                 | 78  |
| 14. Logarithmic functions                                 | 83  |
| 15. The trigonometric ratios                              | 88  |
| 16. Applying right triangles                              | 93  |
| 17. The trigonometric functions and cartesian coordinates | 96  |
| 18. Circles and radian measure                            | 102 |
| 19. The unit circle and the trigonometric functions       | 108 |
| 20. Graphing trigonometric functions                      | 113 |
| 21. Trigonometric identities                              | 114 |
| 22. Practice problems. MATH 06.                           | 115 |

## 1. ROOTS AND RADICALS

- (1) What are the natural numbers?
  
  
  
  
  
  
  
  
  
  
- (2) What are the whole numbers?
  
  
  
  
  
  
  
  
  
  
- (3) What are the integers?
  
  
  
  
  
  
  
  
  
  
- (4) What are the rational numbers?
  
  
  
  
  
  
  
  
  
  
- (5) What are the irrational numbers? Give five examples of irrational numbers.
  
  
  
  
  
  
  
  
  
  
- (6) What is the principal square root?
  
  
  
  
  
  
  
  
  
  
- (7) What is the radicand?
  
  
  
  
  
  
  
  
  
  
- (8) Identify the radicand in each expression:
  - (a)  $\sqrt{18}$
  - (b)  $\sqrt{x^2 + 1}$

(c)  $\sqrt{\frac{x}{y}}$

(9) What is a rational number? Give 5 examples.

(10) Find the square roots:

(a)  $\sqrt{49}$

(b)  $\sqrt{81}$

(c)  $\sqrt{169}$

(d)  $-\sqrt{\frac{49}{81}}$

(11) Explain using 5 examples the statement, “If  $x^n = a$  then  $x = \sqrt[n]{a}$ .”

(12) Explain using 5 examples the statement, “ $\sqrt[n]{x^n} = |x|$  if  $n$  is even.”

(13) Explain using 5 examples the statement, “ $\sqrt[n]{x^n} = x$  if  $n$  is odd.”

(14) The distance formula:

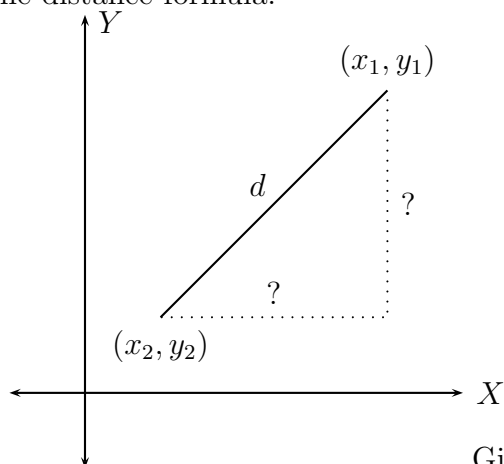

Given two points  $(x_1, y_1)$  and  $(x_2, y_2)$  on the coordinate plane, the distance between them is given by

$$d = \sqrt{(x_1 - x_2)^2 + (y_1 - y_2)^2}.$$

Find the distance between the following pairs of points:

(a)  $(1, 2), (3, 4)$

(b)  $(2, 2), (3, 3)$

(c)  $(1, 1), (1, 1)$

(d)  $(-1, 3), (2, -4)$

(15) Evaluate if possible

(a)  $\sqrt[4]{2^4}$

(b)  $\sqrt[4]{(-2)^4}$

(c)  $\sqrt[3]{-27}$

(d)  $\sqrt[5]{32}$

(e)  $\sqrt[5]{-32}$

(f)  $\sqrt[7]{-128}$

(g)  $\sqrt[4]{81}$

(h)  $\sqrt{81}$

(i)  $\sqrt{x^2}$

(j)  $\sqrt[4]{x^4}$

(k)  $\sqrt[5]{-243n^5}$

(l)  $\sqrt[5]{\frac{-1024m^{10}n^{15}}{u^{20}}}$

(m)  $\sqrt[3]{\frac{27m^{10}n^{15}}{u^{20}}}$

(n)  $\sqrt{\frac{27x^5y^{13}}{z^{20}u^4}}$

(o)  $\sqrt[4]{\frac{32a^{12}b^{11}}{c^9d^{23}}}$

(p)  $\sqrt{x^{45}}$

(q)  $\sqrt[3]{x^{45}}$

(r)  $\sqrt[4]{x^{45}}$

(16) Complete the following table of square roots:

|              |        |        |        |
|--------------|--------|--------|--------|
| $\sqrt{0} =$ | $= 6$  | $= 12$ | $= 18$ |
| $\sqrt{1} =$ | $= 7$  | $= 13$ | $= 19$ |
| $\sqrt{4} =$ | $= 8$  | $= 14$ | $= 20$ |
| $\sqrt{9} =$ | $= 9$  | $= 15$ | $= 30$ |
| $= 4$        | $= 10$ | $= 16$ | $= 40$ |
| $= 5$        | $= 11$ | $= 17$ | $= 50$ |

(17) Complete the following table of cube roots:

|                 |       |       |         |
|-----------------|-------|-------|---------|
| $\sqrt[3]{0} =$ | $= 3$ | $= 6$ | $= 9$   |
| $\sqrt[3]{1} =$ | $= 4$ | $= 7$ | $= 10$  |
| $\sqrt[3]{8} =$ | $= 5$ | $= 8$ | $= 100$ |

(18) Recall: What is an irrational number?

(19) Is the number  $0.777\cdots$  rational or irrational? Explain.**Solution.** Yes, the number  $0.777\cdots$  is rational. Let  $x = 0.777\cdots$ . Then  $10x =$  \_\_\_\_\_.Hence,  $10x - x =$  \_\_\_\_\_  $- 0.777\cdots$ .So,  $9x =$  \_\_\_\_\_.Thus,  $x =$  \_\_\_\_\_, which is a quotient of two integers. Therefore  $x$  is a rational number.(20) Is the number  $0.767676\cdots$  rational or irrational? Explain.

Write down in your notebook the following **important** properties of square roots:

$$\sqrt{a \cdot b} = \sqrt{a} \cdot \sqrt{b}, \quad a \geq 0, b \geq 0$$

$$\sqrt{\frac{a}{b}} = \frac{\sqrt{a}}{\sqrt{b}}, \quad a \geq 0, b > 0$$

$$(\sqrt{a})^2 = a, \quad a \geq 0.$$

Answer the following:

(1) Is  $\sqrt{a^2 + b^2} = a + b$ ? Explain.

(2) Is  $\sqrt{a^2 - b^2} = a - b$ ? Explain.

(3) Is  $\sqrt{\frac{1}{a^2 + b^2}} = \frac{1}{a + b}$ ? Explain.

(4) Is  $\sqrt{\frac{1}{a^2 + b^2}} = \frac{1}{a} + \frac{1}{b}$ ? Explain.

(5) Simplify each square root:

(a)  $\sqrt{45}$

(b)  $\sqrt{72}$

(c)  $\sqrt{192}$

(d)  $\sqrt{121 + 100}$

(e)  $\sqrt{121} + \sqrt{100}$

(f)  $\sqrt{121 - 100}$

(g)  $\sqrt{121} - \sqrt{100}$

(h)  $(\sqrt{5})^2$

(i)  $\sqrt{8} \cdot \sqrt{2}$

(j)  $\sqrt{\frac{169}{9}}$

$$(k) -\sqrt{\frac{900}{289}}$$

$$(l) \frac{3}{\sqrt{6}}$$

$$(m) \frac{5}{\sqrt{5}}$$

$$(n) \frac{7}{\sqrt{17}}$$

$$(o) \frac{1}{\sqrt{11}}$$

$$(p) \sqrt{75}$$

$$(q) \sqrt{200}$$

$$(r) \sqrt{1000}$$

$$(s) \sqrt{\frac{324}{25}}$$

$$(t) \sqrt{\frac{1600}{49}}$$

(6) Simplify each square root:

$$(a) \sqrt{x^8}$$

$$(b) \sqrt{x^9} \quad (x \geq 0)$$

$$(c) \sqrt{\frac{18m^5n^6}{p^{12}q^7}}$$

$$(d) \frac{10mn}{\sqrt{5mn}}$$



(7) Rationalize the denominator:

(a)  $\frac{1}{\sqrt{3}}$

(b)  $\frac{1}{\sqrt[4]{27}}$

(c)  $\frac{abc}{\sqrt{abc}}$

(d)  $\frac{2}{\sqrt[5]{16}}$

(e)  $\frac{15}{\sqrt[3]{5a^2b}}$

(f)  $\frac{12}{\sqrt[4]{a^3b^2c}}$

## 2. OPERATIONS ON RADICAL EXPRESSIONS

Perform the following operations and simplify:

$$(1) \sqrt{2} + 3\sqrt{2}$$

$$(2) \sqrt[3]{4} - 5\sqrt[3]{4}$$

$$(3) \sqrt[4]{9} - 7\sqrt[4]{9} + 12\sqrt[4]{9}$$

$$(4) \sqrt{13} + 9\sqrt{13} - 21\sqrt{13}$$

$$(5) \frac{2\sqrt{5}}{3} - \frac{3\sqrt{5}}{4}$$

$$(6) \frac{3\sqrt[5]{7}}{4} + \frac{5\sqrt[5]{7}}{6}$$

$$(7) \sqrt[3]{15} - \sqrt[5]{15}$$

$$(8) \sqrt{12} - \sqrt{3}$$

$$(9) 3\sqrt{2} + \sqrt{50}$$

$$(10) \sqrt{75} + \sqrt{48} - 7\sqrt{12}$$

$$(11) 3\sqrt{50} - 7\sqrt{8} + 11\sqrt{18}$$

$$(12) \sqrt[3]{40} - 5\sqrt[3]{5}$$

$$(13) 2\sqrt[3]{56} + 4\sqrt[3]{40}$$

$$(14) \sqrt{20p^5} - \sqrt{30p^5}$$

$$(15) \sqrt{3z} - \frac{1}{\sqrt{3z}}$$

$$(16) \sqrt{5} \cdot \sqrt{a}$$

$$(17) \sqrt[3]{12} \cdot \sqrt[3]{a^2}$$

$$(18) \sqrt[4]{18} \cdot \sqrt[3]{a^2}$$

$$(19) \sqrt{5}(\sqrt{3} - \sqrt{a})$$

$$(20) (\sqrt[3]{12} + \sqrt[3]{5})(\sqrt[3]{x} + \sqrt[3]{y})$$

$$(21) (\sqrt{12} + \sqrt{5})(\sqrt{12} - \sqrt{5})$$

$$(22) (\sqrt{5})^2 + 2(\sqrt{5})(\sqrt{3}) + (\sqrt{3})^2$$

$$(23) (\sqrt{5} + \sqrt{3})^2$$

$$(24) (\sqrt{5})^2 + (\sqrt{3})^2$$

$$(25) (\sqrt[3]{a} - \sqrt[3]{b})(\sqrt[3]{a^2} + \sqrt[3]{a}\sqrt[3]{b} + \sqrt[3]{b^2})$$

$$(26) (\sqrt[3]{a} + \sqrt[3]{b})(\sqrt[3]{a^2} - \sqrt[3]{a}\sqrt[3]{b} + \sqrt[3]{b^2})$$

$$(27) (\sqrt[4]{a^2} + \sqrt[4]{b^2})(\sqrt[4]{a^2} - \sqrt[4]{b^2})$$

$$(28) (\sqrt{a})^2 - 2(\sqrt{a})(\sqrt{b}) + (\sqrt{b})^2$$

$$(29) (\sqrt{a} - \sqrt{b})^2$$

$$(30) (\sqrt{a})^2 - (\sqrt{b})^2$$

Rationalize the denominator:

$$(1) \frac{1}{\sqrt{3}}$$

$$(2) \frac{1}{2 + \sqrt{3}}$$

$$(3) \frac{1}{2 - \sqrt{3}}$$

$$(4) \frac{4 + \sqrt{5}}{4 - \sqrt{5}}$$

$$(5) \frac{1}{\sqrt[3]{a} - 2} \text{ (Hint: Difference of cubes formula)}$$

$$(6) \frac{1}{\sqrt[3]{a} + 2} \text{ (Hint: Sum of cubes formula)}$$

## 3. SOLVING RADICAL EQUATIONS

Solve for the variable. Remember to **check** your answer in the original equation.

$$(1) \sqrt{x} = 4$$

$$(2) \sqrt{x+2} = 4$$

$$(3) 2\sqrt{x-2} + 3 = 4$$

$$(4) \frac{2}{3}\sqrt{x-4} + \frac{1}{4} = \frac{5}{6}$$

$$(5) \sqrt{3x-4} + 2 = 0$$

$$(6) \sqrt{x+17} + 3 = x$$

$$(7) \sqrt{3x+5} - 3x = -1$$

$$(8) \sqrt{2c-1} = \sqrt{3c+1} - 1$$

$$(9) \sqrt{5y+6} - \sqrt{3y+4} = 2$$

$$(10) \sqrt{x^2+2x} - 2\sqrt{6} = 0$$

$$(11) \frac{\sqrt{x-2}}{x-2} = \frac{x-5}{\sqrt{x-2}}$$

$$(12) \sqrt{\sqrt{s}-7} = \sqrt{s-7}$$

$$(13) \sqrt{4+x} = \sqrt{x+4}$$

$$(14) \sqrt{3-x} = \sqrt{x-3}$$

## 4. RATIONAL EXPONENTS

Assume that all the variables are positive. Simplify and present your solutions with positive exponents.

(1)  $y^{-2}$

(2)  $\frac{x^2y^{-3}}{s^{-4}}$

(3)  $\frac{a^2b^{-3}}{c^{-10}d^4}$

(4)  $(a^2)^3$

(5)  $(a^{-2})^3$

(6)  $(4x^2y^{-3}z^2)^2$

(7)  $\frac{(a^2)^{-3}(b^{-3})^{-2}}{(c^{-2})^5(d^{-2})^{-4}}$

(8)  $(25)^{\frac{1}{2}}$

(9)  $(-49)^{\frac{1}{2}}$

(10)  $-(49)^{\frac{1}{2}}$

(11)  $(-125)^{\frac{1}{3}}$

(12)  $-(125)^{\frac{1}{3}}$

(13)  $(-32)^{\frac{1}{5}}$

(14)  $32^{-\frac{3}{5}}$

(15)  $\left(-\frac{27}{8}\right)^{\frac{1}{3}}$

(16)  $\left(\frac{9}{4}\right)^{-\frac{1}{2}}$

(17)  $(25)^{\frac{3}{2}}$

(18)  $-(49)^{-\frac{3}{2}}$

(19)  $(-49)^{-\frac{3}{2}}$

$$(20) \left(\frac{16}{9}\right)^{-\frac{3}{2}}$$

$$(21) (25)^{-\frac{1}{2}}$$

$$(22) (125)^{-\frac{1}{3}}$$

$$(23) (a^{-2})^{\frac{1}{3}}$$

$$(24) \left(\frac{a^{\frac{3}{2}}b^{-\frac{2}{3}}}{c^{-\frac{1}{3}}}\right)^{\frac{2}{5}}$$

$$(25) \left(\frac{32^{-1}x^{-\frac{5}{2}}y^{-\frac{4}{3}}}{243z^5}\right)^{\frac{3}{5}}$$

$$(26) \left(\frac{9x^{\frac{3}{2}}z^5}{4^{-1}y^{-\frac{1}{3}}}\right)^{\frac{1}{2}}$$

$$(27) (x^{\frac{1}{3}} + y^{\frac{1}{5}})(x^{\frac{1}{3}} - y^{\frac{1}{5}})$$

$$(28) (a^{\frac{1}{5}} + b^{\frac{1}{7}})^2$$

$$(29) (a^{\frac{1}{5}})^2 + (b^{\frac{1}{7}})^2$$

Factor:

$$(1) x^2 - 4x + 3$$

$$(2) x^{\frac{4}{5}} - 4x^{\frac{2}{5}} + 3$$

$$(3) x^4 - 16$$

$$(4) x^{\frac{4}{5}} - b^{\frac{4}{5}}$$

$$(5) w^2 + 8w - 20$$

$$(6) w^{\frac{4}{3}} + 8w^{\frac{2}{3}} - 20$$



## 5. COMPLEX NUMBERS

$$i = \sqrt{-1}$$

Perform the following operations:

$$(1) \sqrt{-4}$$

$$(2) \sqrt{-9}$$

$$(3) \sqrt{-16}$$

$$(4) \sqrt{-25}$$

$$(5) \sqrt{-\frac{169}{9}}$$

$$(6) \sqrt{-\frac{25}{49}}$$

$$(7) \sqrt{-5}$$

$$(8) \sqrt{-3}$$

$$(9) \sqrt{-12}$$

$$(10) \sqrt{-75}$$

$$(11) (5 + 4i) + (3 + 7i)$$

$$(12) (5 + 4i) - (3 + 7i)$$

$$(13) (-5 + 4i) + (3 - 7i)$$

$$(14) (30 - 15i) - (2 + 5i) + (-8 + 3i)$$

$$(15) (30 - 15i) - [(2 + 5i) + (-8 + 3i)]$$

$$(16) \left(\frac{2}{3} + \frac{5}{4}i\right) - \left(\frac{4}{7} - \frac{8}{3}i\right)$$

$$(17) - \left[ \left( \frac{4}{7} - \frac{8}{3}i \right) - \left( \frac{1}{42} + \frac{i}{12} \right) \right]$$

$$(18) 5(3 + 4i)$$

$$(19) -5(3 + 4i)$$

$$(20) 5i(3 + 4i)$$

$$(21) \sqrt{-8}\sqrt{-2}$$

$$(22) \sqrt{-4}\sqrt{-9}$$

$$(23) \sqrt{-25}\sqrt{-36}$$

$$(24) \sqrt{-5}\sqrt{-6}$$

$$(25) \sqrt{-3}\sqrt{-2}$$

$$(26) (1 + 5i)(3 + 4i)$$

$$(27) (-1 - 2i)(-3 - 4i)$$

$$(28) (4 - 5i)(5 + 12i)$$

$$(29) i(3 - 4i)$$

$$(30) (4 + 5i)^2$$

$$(31) (4 - 5i)^2$$

$$(32) (4 + 5i)^3$$

$$(33) (4 - 5i)^3$$

$$(34) (4 + 5i)(4 - 5i)$$

$$(35) \left(\frac{1}{2} + \frac{2}{3}i\right) \left(\frac{1}{3} - \frac{3}{4}i\right)$$

$$(36) i^2$$

$$(37) i^3$$

$$(38) i^4$$

$$(39) i^9$$

$$(40) i^{12}$$

$$(41) i^{30}$$

$$(42) i^{100}$$

$$(43) i^{110}$$

$$(44) \frac{3 + 4i}{5}$$

$$(45) \frac{3 + 4i}{-5}$$

$$(46) \frac{3 + 4i}{5i}$$

$$(47) \frac{3 + 4i}{-5i}$$

$$(48) \frac{3 + 4i}{1 + 5i}$$

$$(49) \frac{-4 - 3i}{-1 - 2i}$$

$$(50) \frac{5 + 12i}{4 - 5i}$$

$$(51) \frac{i}{3 - 4i}$$

$$(52) \frac{1}{3 - 4i}$$

$$(53) \frac{1}{5 + 12i}$$

$$(54) \frac{1}{-3 - 4i}$$

$$(55) \frac{\left(\frac{2}{3} + \frac{1}{2}i\right)}{\left(\frac{1}{2} - \frac{1}{3}i\right)}$$

$$(56) \frac{(\sqrt{3} + \sqrt{5}i)}{(\sqrt{2} - \sqrt{7}i)}$$

$$(57) \frac{\left(-\frac{1}{2} - \frac{1}{2}i\right)}{\left(\frac{1}{3} - \frac{2}{3}i\right)}$$

$$(58) \frac{(-\sqrt{7} + \sqrt{3}i)}{(-\sqrt{5} + \sqrt{7}i)}$$

## 6. SOLVING QUADRATIC EQUATIONS

(1) Solve for  $x$

(a)  $x(x - 2)(x + 3)(x - 5) = 0$

(b)  $x(x - 8)(x + 11)(x - 100)(x + 2000) = 0$

(2) Solve for  $x$  by the factoring method:

(a)  $x^2 - 2x = 0$

(b)  $x^2 - 2x = 8$

(c)  $4x^2 + 4x = \frac{15}{2} + 5x.$

(d)  $(x - 2)(x + 2) + x = \frac{8x}{3}.$

(e)  $-4 = \frac{2x(x - 5)}{3}.$

(f)  $-2x^2 = \frac{x - 35}{3}.$

(g)  $6x(x + 1) = 20 - x$ .

(h)  $\frac{-7}{2}x^2 - \frac{7}{2} = 18x - 1$ .

(3) For each of the following problems, solve for  $x$ .

(a)  $x^2 - 25 = 0$

(b)  $x^2 - 16 = 0$

(c)  $x^2 - 15 = 0$

(d)  $2x^2 - 5 = 0$

(e)  $3x^2 - 12 = 0$

$$(f) 9x^2 - 1 = 0$$

$$(g) 7x^2 - 8 = 0$$

$$(h) 10x^2 - 11 = 0$$

(4) Solve.

$$(a) x^2 + 25 = 0$$

$$(b) x^2 + 15 = 0$$

$$(c) 2x^2 + 5 = 0$$

$$(d) 9x^2 + 1 = 0$$

(5) Solve for  $x$ :

(a)  $3x^2 + 5x = 0$

(b)  $x^2 - 16x = 0$

(c)  $x^2 - 25x = 0$

(d)  $7x^2 + 5x = 0$

(e)  $10x^2 + 11x = 0$

(6) Recall:

$$(x + y)^2 =$$

$$(x - y)^2 =$$

(7) Fill in the blanks:

(a)  $x^2 + 6x = x^2 + 6x + 9 - 9 = (x + 3)^2 - 9$ .

(b)  $x^2 - 6x =$  \_\_\_\_\_.

(c)  $x^2 + 4x =$  \_\_\_\_\_.

(d)  $x^2 - 4x =$  \_\_\_\_\_.

(e)  $x^2 + 2x =$  \_\_\_\_\_.

(f)  $x^2 - 2x =$  \_\_\_\_\_.

(g)  $x^2 + 8x =$  \_\_\_\_\_.

(h)  $x^2 - 8x =$  \_\_\_\_\_.

(i)  $x^2 + 3x =$  \_\_\_\_\_.

(j)  $x^2 - 3x =$  \_\_\_\_\_.



(k)  $x^2 + x = \underline{\hspace{10em}}$ .

(l)  $x^2 - x = \underline{\hspace{10em}}$ .

(m)  $x^2 + 7x = \underline{\hspace{10em}}$ .

(n)  $x^2 - 7x = \underline{\hspace{10em}}$ .

(o)  $x^2 + kx = \underline{\hspace{10em}}$ .

(8) Solve by completing the square:

(a)  $x^2 - 6x + 5 = 0$ .

**Solution.**     • *Subtract 5 from both sides*• *Add  $3^2$  to both sides. (Can you guess why  $3^2$ ?)*• *Simplify both sides.*• *Is the left hand side a square formula? If so, then write it down.*• *Take square root of both sides (remember to consider the positive and negative options)*• *Solve for  $x$ . There should be two answers.*

(b)  $x^2 - 8x - 15 = 0$

**Solution.**     • *Add 15 to both sides*• *Add  $4^2$  to both sides. (Can you guess why  $4^2$ ?)*• *Simplify both sides.*• *Is the left hand side a square formula? If so, then write it down.*

- Take square root of both sides (remember to consider the positive and negative options)
- Solve for  $x$ . There should be two answers.

(c)  $x^2 - 9x + 18 = 0$ .

**Solution.**     • Subtract 18 from both sides

- Add  $\left(\frac{9}{2}\right)^2$  to both sides. (Can you guess why  $\left(\frac{9}{2}\right)^2$ ?)
- Simplify both sides.
- Is the left hand side a square formula? If so, then write it down.
- Take square root of both sides (remember to consider the positive and negative options)
- Solve for  $x$ . There should be two answers.

(d)  $x^2 - 10x + 21 = 0$

(e)  $2x^2 - 20x + 4 = 0$  (First divide by 2 throughout and then proceed just as above).

(f)  $x^2 - \frac{3}{2}x - \frac{7}{2} = 0$

(g)  $2x^2 - 5x + 3 = 0$  (First divide by 2 throughout and then proceed just as above).

(h)  $3x^2 + 11x - 4 = 0$  (What will you first divide by?)

(i)  $5x^2 - 17x - 6 = 0$

(9) We now have enough practice to work on the **general** case and derive the **Quadratic formula**.

Solve for  $x$  in  $ax^2 + bx + c = 0$  where  $a \neq 0$ . (Do not let the variables trouble you).

**Solution.** • Divide by \_\_\_\_\_ throughout.

• Subtract \_\_\_\_\_ from both sides

• Add \_\_\_\_\_ to both sides.

- *Simplify both sides.*
- *Is the left hand side a square formula? If so, then write it down.*
- *Take square root of both sides (remember to consider the positive and negative options)*
- *Solve for  $x$ . There should be two answers.*

(10) The quadratic formula is:

$$x = \frac{-b \pm \sqrt{b^2 - 4ac}}{2a}$$

Does your formula from problem (3) look like this one? If not, then can you simplify your formula to look like this one?

(11) Solve for  $x$  by using the quadratic formula and **simplify**:

(a)  $x^2 - 6x + 5 = 0$

(b)  $x^2 - 8x - 15 = 0$

(c)  $x^2 - 10x + 21 = 0$

(d)  $x^2 - 9x + 18 = 0$

(e)  $x^2 - \frac{3}{2}x - \frac{7}{2} = 0$

(f)  $2x^2 - 5x + 3 = 0$

(g)  $3x^2 + 11x - 4 = 0$

(h)  $5x^2 - 17x - 6 = 0$

(12) In these word-problems, state **clearly and completely** what your variables stand for.

(a) The area of a square is  $81 \text{ ft}^2$ . Find the length of a side.

(b) If 5 is added to the product of two consecutive odd integers, then the result is 104. What are the integers? (There should be two pairs).

(c) The sum of a number and its reciprocal is 3. Find the number. (There should be two numbers).

(d) A number is equal to its reciprocal plus 5. Find the number. (There should be two numbers).

- (e) The length of a rectangle is 3 times its width. If the area of the rectangle is 22 sq. ft. then find the width of the rectangle.
- (f) One-third the difference of the square of a number and three is the difference between 2 and the same number. Find the number.
- (g) The product of a number and the sum of the number and three is five-sixths the difference of the same number and 1. Find the number.

## 7. INTRODUCTION TO PARABOLAS

- (1) Draw the parabola given by the given equation. What is the vertex? Does the parabola open up or down? What are its  $X$  and  $Y$  intercepts? What is its axis of symmetry, and give two points on the parabola symmetric with respect to the axis of symmetry. What is the domain and range for this graph?

(a)  $y = x^2$

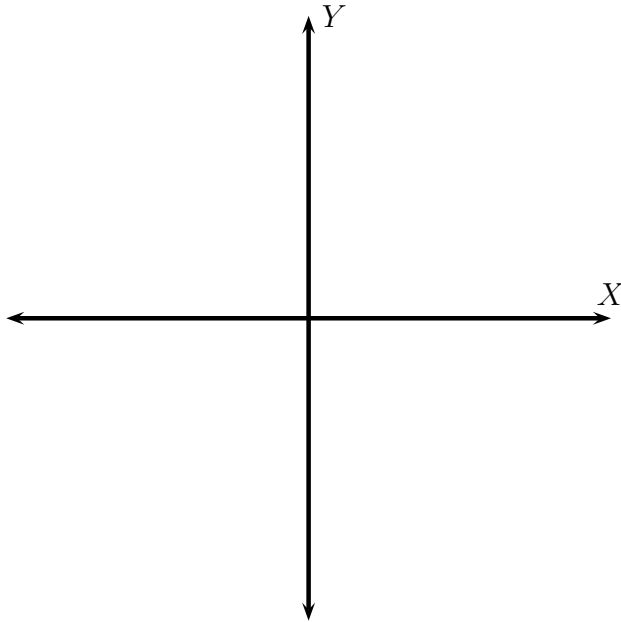

(b)  $y = -x^2$

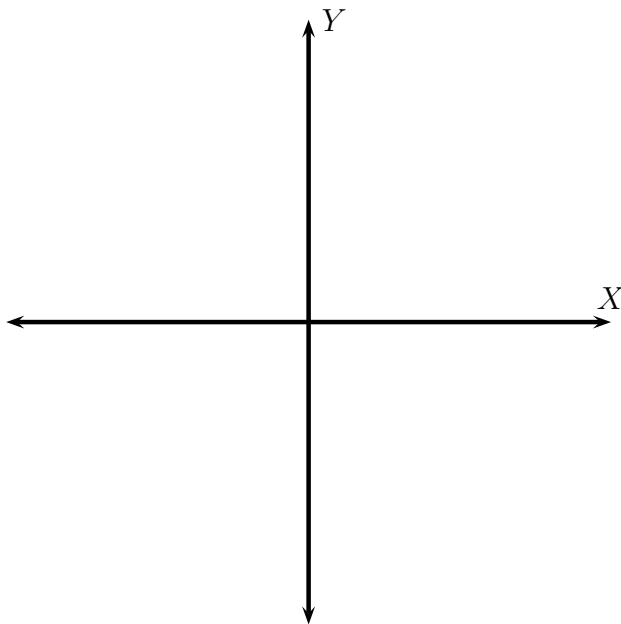



(c)  $y = (x + 3)^2$

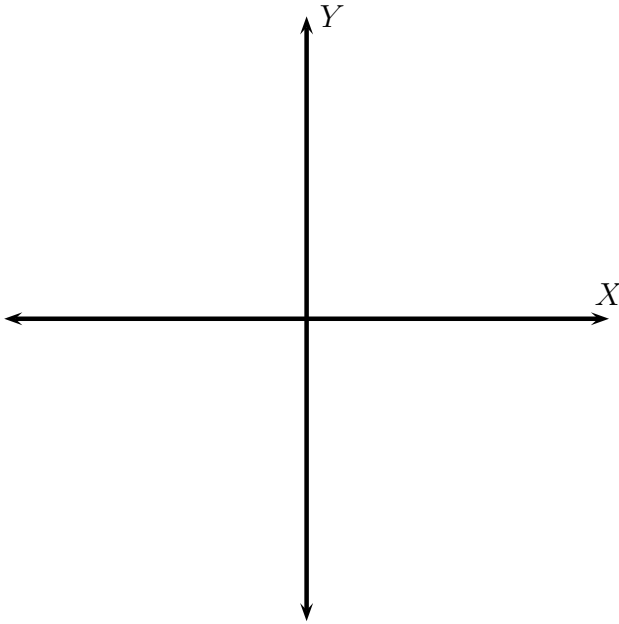

(d)  $y = -(x - 4)^2 + 2.$

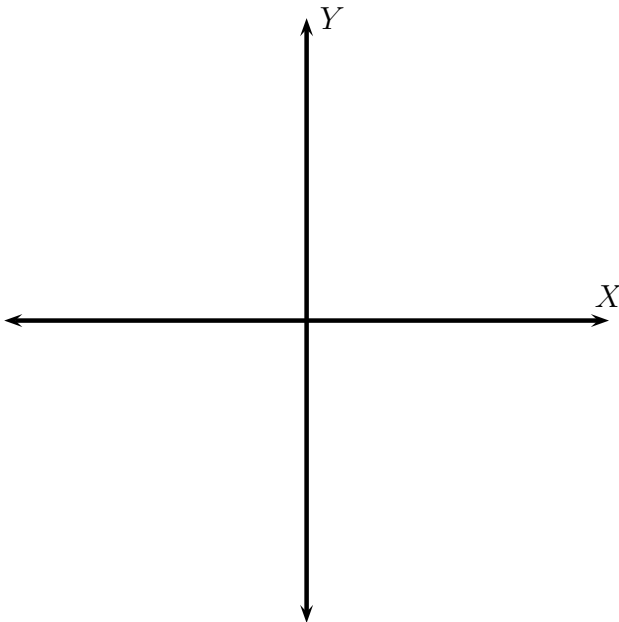

In general, the curve given by the equation  $y = ax^2 + bx + c$  for  $a \neq 0$  is a parabola with vertex whose  $x$  coordinate is given by  $x = \frac{-b}{2a}$ , and which opens up if  $a > 0$ , or opens down if  $a < 0$ .

(e)  $y = x^2 - 2x$

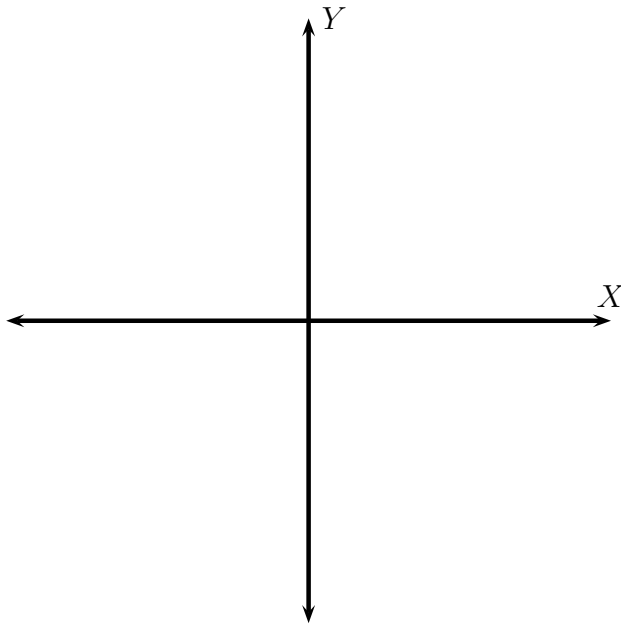

(f)  $y = -x^2 + 2x + 2$

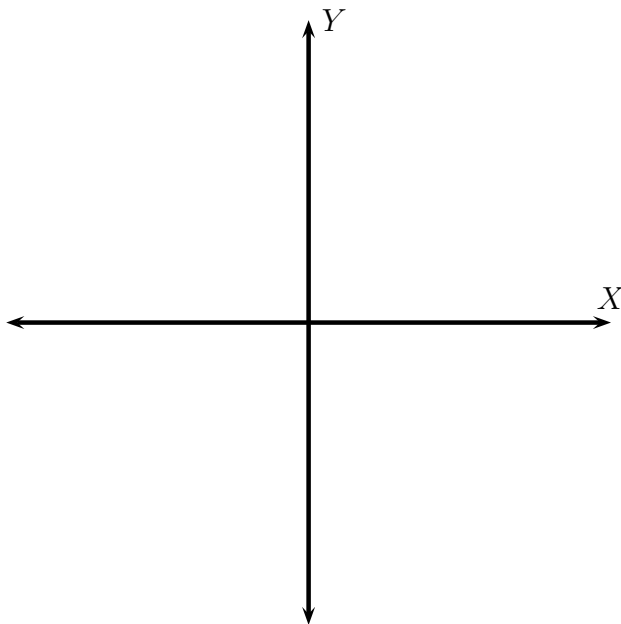

$$(g) y = -\frac{x^2}{3} - 2x - 2$$

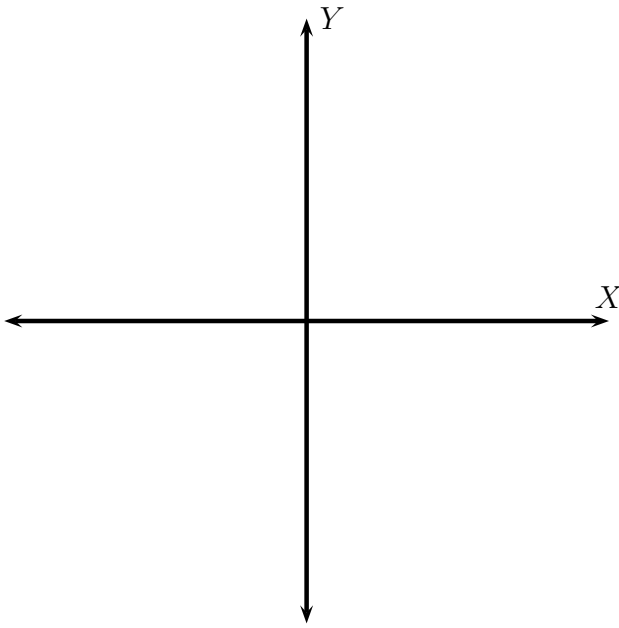

$$(h) y = -3x^2 + 12x - 11$$

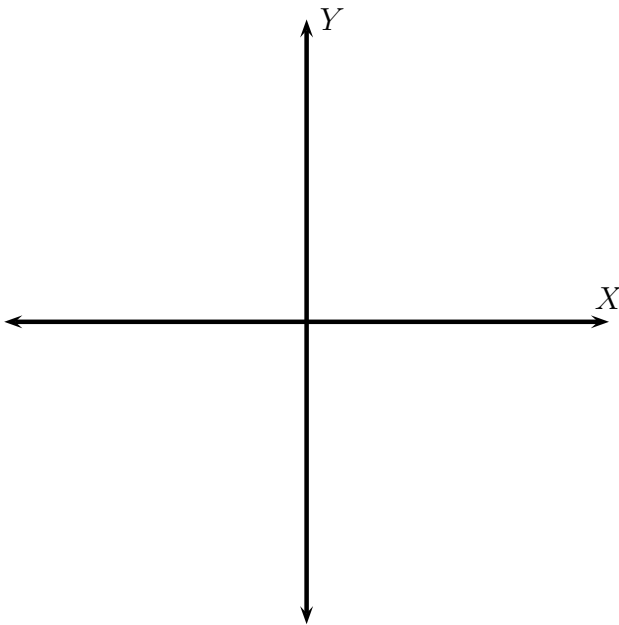

(2) A projectile is launched into the air from the surface of planet A. On planet A, the height of any projectile  $y$  given in feet is determined by the equation  $y = -6t^2 + v_0t$ , where  $t$  is time in seconds and  $v_0$  is the initial velocity of the object in feet per second. If the projectile is launched from the ground level with an initial velocity of 400 feet per second, then how many seconds will it take for the projectile to reach a height of 2506 feet?

(3) At a local frog jumping contest, Rivet's jump can be approximated by the equation  $y = -\frac{x^2}{4} + x$  and Croak's jump can be approximated by  $y = -3x^2 + 6x$  where  $x =$  length of the jump in feet and  $y =$  height of the jump in feet.

- Which frog jumped higher? How high did it jump?

- Which frog jumped farther? How far did it jump?

## 8. SIMPLIFYING RATIONAL EXPRESSIONS

(1) Simplify

(a)  $\frac{15}{3}$

(b)  $\frac{2}{14}$

(c)  $\frac{0}{3}$

(d)  $\frac{2}{0}$

(e)  $\frac{0}{0}$

(f)  $\frac{18}{0}$

(2) Give five examples and five nonexamples of a polynomial in variable  $x$ .(3) Give five examples and five nonexamples of a rational function (why the name rational?) in variable  $x$ .

(4) Evaluate the following expressions for the given values of the variable:

(a)  $x^2 + 6x + 9$

$x = 0$

$x = 2$

$x = -2$

$x = 3$

$x = -3$

$x = 1$

(b)  $(x + 3)^2$

$x = 0$

$x = 2$

$x = -2$

$x = 3$

$x = -3$

$x = 1$

(c)  $x^2 + 9$

$x = 0$

$x = 2$

$x = -2$

$x = 3$

$x = -3$

$x = 1$

(d)  $x^3 - 6x^2 + 12x - 8$

$x = 0$

$x = 2$

$x = -2$

$x = 3$

$x = -3$

$x = 1$

(e)  $(x - 2)^3$

$x = 0$

$x = 2$

$x = -2$

$x = 3$

$x = -3$

$x = 1$

(f)  $x^3 - 8$

$x = 0$

$x = 2$

$x = -2$

$x = 3$

$x = -3$

$x = 1$

(g)  $\frac{x + 3}{x - 2}$

$x = 0$

$x = 2$

$x = -2$

$x = 3$

$x = -3$

$x = 1$

$$(h) \frac{x+5}{x(x-2)(x+3)}$$

$$x = 0$$

$$x = 2$$

$$x = -2$$

$$x = 3$$

$$x = -3$$

$$x = 1$$

(5) Recall and memorize some important formulae from MTH 05

- $x^2 - y^2 =$
- $x^3 - y^3 =$
- $x^3 + y^3 =$
- $(x + y)^2 =$
- $(x - y)^2 =$

**Review on factoring:** Factor the following:

(1)  $2x - 20$

(2)  $22x^2 - 18x^3y$

(3)  $12x(a + b) - 28y(b + a)$

(4)  $15a(a + b) - 25b(a + b)$

(5)  $2x(2x - 3y) + 3y(2x - 3y)$

(6)  $14ac + 6ad + 35bc + 15bd$

(7)  $4rt + ru - 12st - 3su$

(8)  $54ac + 66ad - 9bc - 11bd$



$$(9) 6pr - 15ps - 8qr + 20qs$$

$$(10) a^2 - b^2$$

$$(11) x^2 - y^2$$

$$(12) \alpha^2 - \beta^2$$

$$(13) (2x)^2 - (3y)^2$$

$$(14) 4a^2 - 9b^2$$

$$(15) 16a^3 - 25ab^2$$

$$(16) 12x^2y^4 - 27x^4y^2$$

$$(17) 3a^2 - 5b^2$$

$$(18) x^8 - y^4$$

$$(19) x^4y^8 - a^4b^4$$

$$(20) a^3 - b^3$$

$$(21) x^3 - y^3$$

$$(22) \alpha^3 - \beta^3$$

$$(23) (2x)^3 - (3y)^3$$

$$(24) 8a^3 - 27b^3$$

$$(25) 64a^4 - 125ab^3$$

$$(26) 48x^2y^5 - 6x^5y^2$$

$$(27) x^9 - y^6$$

$$(28) x^6y^9 - a^6b^9$$

$$(29) a^3 + b^3$$

$$(30) x^3 + y^3$$

$$(31) \alpha^3 + \beta^3$$

$$(32) (2x)^3 + (3y)^3$$

$$(33) 8a^3 + 27b^3$$

$$(34) 64a^4 + 125ab^3$$

$$(35) 48x^2y^5 + 6x^5y^2$$

$$(36) x^9 + y^6$$

$$(37) x^6y^9 + a^6b^9$$

$$(38) x^2 + 5x + 6$$

$$(39) x^2 - 5x + 6$$

$$(40) x^2 + 7x + 6$$

$$(41) x^2 - x - 6$$

$$(42) x^2 + 5x - 6$$

$$(43) x^2 + x - 6$$

$$(44) x^2 - 5x - 6$$

$$(45) x^2 - 7x + 6$$

$$(46) a^2 + 13a + 30$$

$$(47) a^2 + 7a - 30$$

$$(48) a^2 - 7a - 30$$

$$(49) a^2 - 13a + 30$$

$$(50) a^2 - 13a - 30$$

$$(51) a^2 + 13a - 30$$

$$(52) a^2 + 19a + 18$$

$$(53) a^2 + 11a + 18$$

$$(54) a^2 - 19a + 18$$

$$(55) a^2 + 7a - 18$$

$$(56) a^2 + 17a - 18$$

$$(57) a^2 - 7a - 18$$

$$(58) a^2 - 17a - 18$$

$$(59) a^2 + 2ab - 24b^2$$

$$(60) x^2 - 12xy - 64y^2$$

$$(61) \alpha^4 + \alpha^2\beta^2 - 2\beta^4$$

$$(62) (x + y)^2 + 17(x + y)(a - b) + 30(a - b)^2$$

$$(63) (2x - y)^2 + 19(2x - y)(a + b) + 48(a + b)^2$$

$$(64) x^4 - 13x^2y^2 + 36y^4$$

$$(65) 6a^2 + 23a + 20$$

$$(66) 6a^2 + 34a + 20$$

$$(67) 6a^2 + 7a - 20$$

$$(68) 6a^2 - 23a + 20$$

$$(69) 6a^2 + 2a - 20$$

$$(70) 6a^2 - 34ab + 20b^2$$

$$(71) 6a^2 - 7ab - 20b^2$$

$$(72) 6a^2 - 2ab - 20b^2$$



$$(73) 35h^2 - 87hk + 22k^2$$

$$(74) 35h^2 + 117hk + 22k^2$$

$$(75) 35h^2 + 67hk - 22k^2$$

$$(76) 35h^2 + 103hk - 22k^2$$

$$(77) 35h^2 - 67hk - 22k^2$$

$$(78) 35h^2 - 103hk - 22k^2$$

$$(79) 35h^2 - 117hk + 22k^2$$

$$(80) 35h^2 + 87hk + 22k^2$$

$$(81) 48a^4 - 82a^2b^2 + 35b^4$$

$$(82) 48a^4 - 2a^2b^2 - 35b^4$$

$$(83) 48a^4 + 2a^2b^2 - 35b^4$$

$$(84) 48a^4 + 82a^2b^2 + 35b^4$$

$$(85) 49h^4 + 70h^2k^2 + 25k^4$$

$$(86) 49h^4 - 70h^2k^2 + 25k^4$$

$$(87) 6(x + y)^2 + 31(x + y)(a - b) + 35(a - b)^2$$

$$(88) 6(x - y)^2 - 31(x - y)(a + b) + 35(a + b)^2$$

$$(89) 6x^4 - 35x^2y^2 + 25y^4$$

**End of Review on factoring**

(1) For what values of the variables are the following expressions undefined? For what values of the variables are the following expressions equal to 0?

(a)  $\frac{(x+1)}{x}$

(b)  $\frac{(x+1)}{x(x+2)}$

(c)  $\frac{(x+1)}{(x+2)(x+1)}$

(d)  $\frac{1}{(x+1)}$

(e)  $\frac{(x-1)}{(x+3)(x-2)}$

(f)  $\frac{(x-1)}{x^2+x-6}$

(g)  $\frac{(x+5)(x-3)}{x(x+7)}$

$$(h) \frac{x^2 + 2x - 15}{x^2 + 7x}$$

$$(i) \frac{x^2 - 8x + 15}{x^2 + 7x - 8}$$

$$(j) \frac{x^2 + 8x - 20}{x^2 + 9x + 20}$$

$$(k) \frac{x^3 + 13x^2 + 42x}{x^2 - 5x - 24}$$

$$(l) \frac{6x^2 - 7x - 5}{4x^2 + 3x - 1}$$

$$(m) \frac{10x^3 - x^2 - 21x}{9x^2 - 12x + 4}$$

$$(n) \frac{x^2 - 9}{x^2 - 4}$$

$$(o) \frac{9x^2 - 1}{25x^2 - 1}$$

$$(p) \frac{9x^2 - 4}{25x^2 - 9}$$

$$(q) \frac{x^2 - 5}{x^2 - 3}$$

$$(r) \frac{x^2 - 7}{3x^2 - 5}$$

(2) Simplify:

$$(a) \frac{75}{125}$$

$$(b) \frac{32}{160}$$

$$(c) \frac{42x^2y^3z}{12x^8yz^9}$$

$$(d) \frac{(2x^3 - 4x^2)(x + 3)}{8x(x + 2)(x - 2)}$$

$$(e) \frac{2x^4 + 2x^3 - 12x^2}{8x^3 - 32x}$$

$$(f) \frac{3x^3 + 27x^2 + 42x}{4x^4 + 8x^3 - 140x^2}$$

$$(g) \frac{3x^2 - 14x - 5}{x^2 - 25}$$

$$(h) \frac{14x^3 - 31x^2 - 10x}{6x^3 - 5x^2 - 25x}$$

$$(i) \frac{x - y}{y - x}$$

$$(j) \frac{a - b}{b - a}$$

$$(k) \frac{a^2 + 6a + 9}{a^2 - 9}$$

$$(l) \frac{x^3 - 27}{9 - x^2}$$

$$(m) \frac{x^3 + 8}{x^4 - 16}$$

$$(n) \frac{x^3 - 8}{x^3 + 2x^2 + 4x}$$

(3) **Review on slope and linear equations.**

**Slope** of a non vertical line passing through two points  $(x_1, y_1)$  and  $(x_2, y_2)$  is

$$m = \text{Slope} = \frac{y_2 - y_1}{x_2 - x_1}.$$

**Slope of a vertical line is undefined.** (Do not use the phrase “no slope.” The phrase “no slope” is ambiguous. It could mean undefined slope, or zero slope).

(a) Find the slope of a line passing through the given points. In each case explain what the slope means.

- $(1,2)$  and  $(2,5)$ .
  
- $(1,-2)$  and  $(1,5)$ .
  
- $(-1,-4)$  and  $(2,-3)$ .
  
- $(-1, -4)$  and  $(2, -4)$ .

**Properties of slope:**

- **Two non-vertical lines with slopes  $m_1$  and  $m_2$  are parallel if  $m_1 = m_2$ .**
- **Two non-vertical lines with slopes  $m_1$  and  $m_2$  are perpendicular if  $m_1 m_2 = -1$ .**
- **Two vertical lines are parallel.**
- **A vertical line is perpendicular to a horizontal line.**

**Equation of a line :**

- The **slope-intercept** equation of a line is  $y = mx + b$  where  $m$  is the slope and  $b$  is the y-intercept of the line.
  - The **point-slope** equation of a line passing through point  $(a, b)$  with slope  $m$  is  $(y - b) = m(x - a)$ .
  - The **standard** form of an equation of a line is  $Ax + By = C$  where  $A, B, C$  are real numbers.
- (a) Write the standard form of the equation for the line that passes through  $(1, 2)$  and is parallel to the line given by the equation  $2x + 3y = 5$ .

- (b) Give the equation in standard form of a line that has slope  $\frac{2}{3}$  and y-intercept  $-3$ . Draw the line.

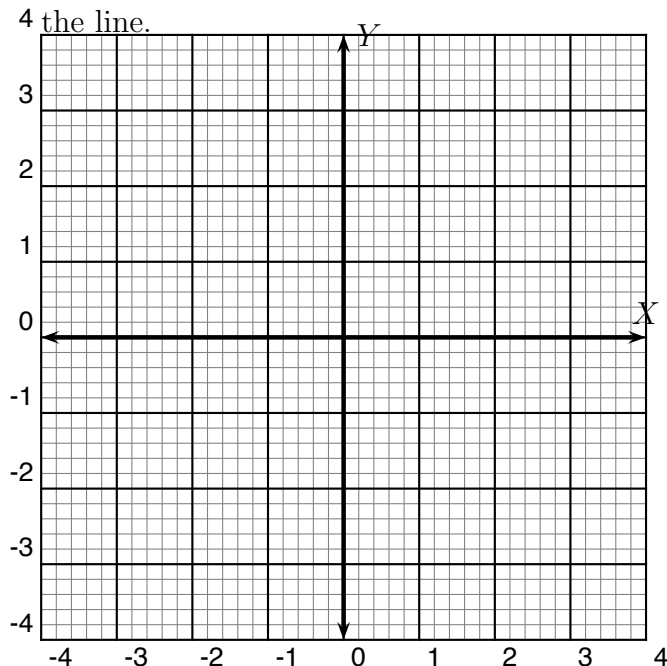

- (c) Give the equation in standard form of a line that has slope  $-\frac{1}{3}$  and passes through  $(1, 2)$ . Draw the line.

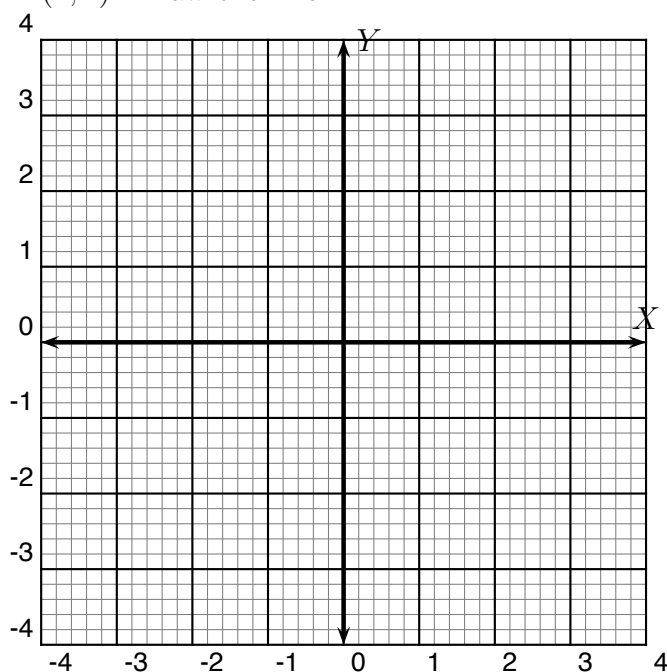

- (d) Write the standard form of the equation for the line that passes through the point  $(-1, -3)$  and is perpendicular to the line given by the equation  $-5x + 2y = 5$ .



- (e) Give the equation in standard form of a line passing through points  $(-1, 2)$  and  $(2, 3)$ .

Draw the line.

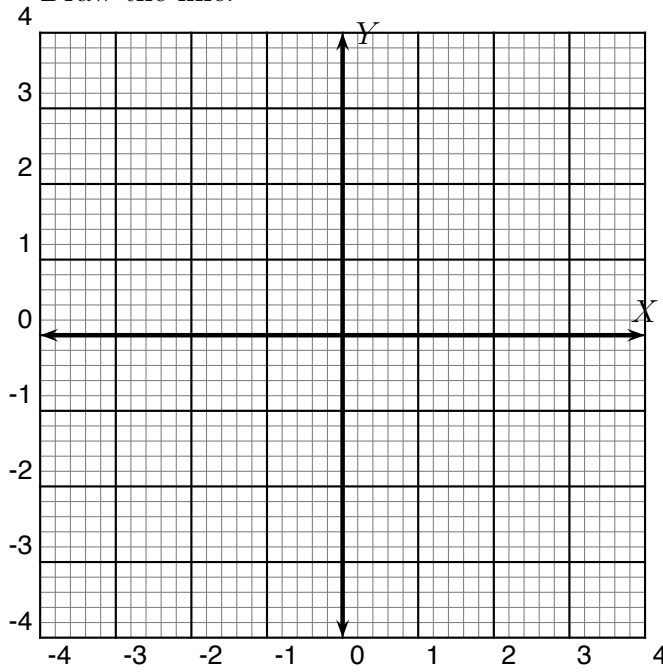

- (f) Draw the line given by the equation  $2x + 3y = 6$ .

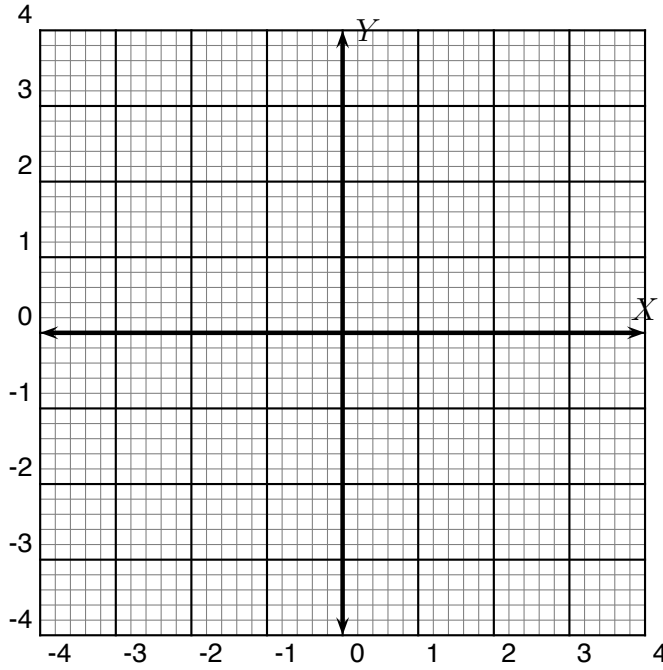

- (g) Write the equation of the vertical line passing through the point  $(3, 2)$ .

- (h) Draw the line given by the equation  $3x + 5y = 15$ .

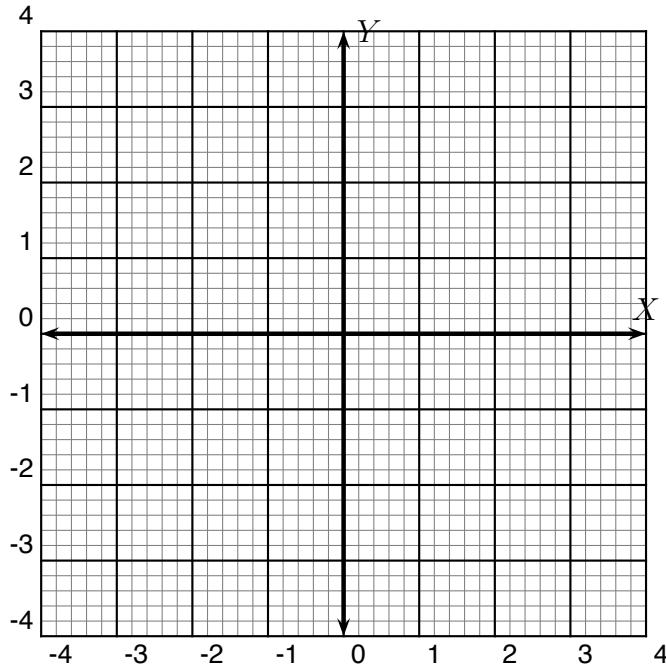

- (i) Draw the line given by the equation  $y = -3x + 5$ .

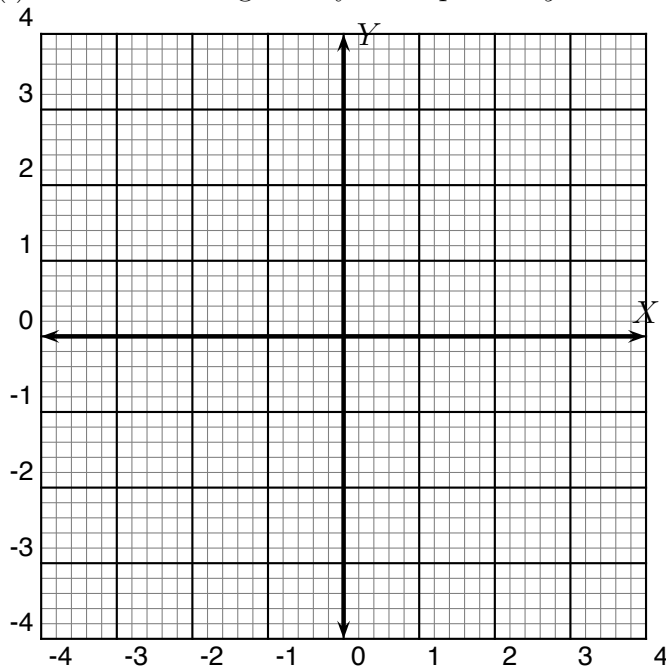

- (j) Write the equation of the horizontal line passing through point  $(3, 2)$ .

**End of review.**

- (4)
- What is the difference between the two functions.
  - Draw their respective graphs.
  - Indicate the  $x$  values where the functions are undefined.
  - Write down their domains.

(a)  $f(x) = 2x + 3$  and  $g(x) = \frac{(2x + 3)(x - 1)}{(x - 1)}$

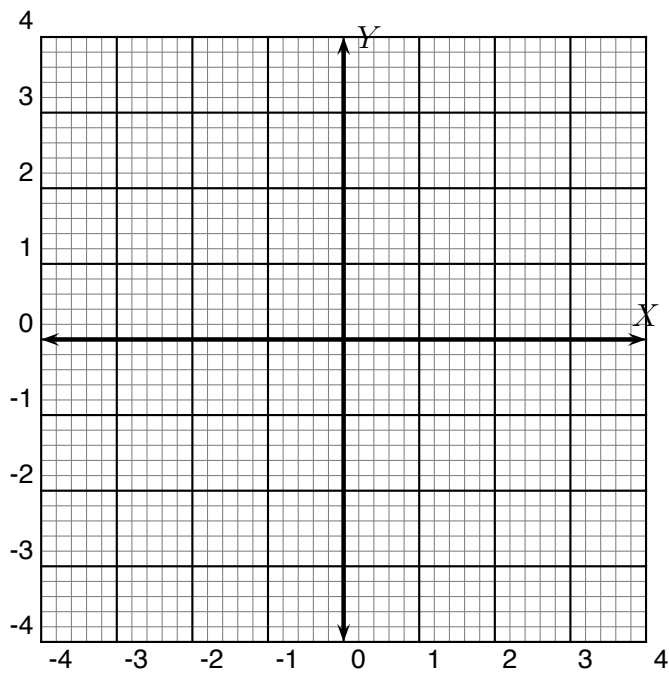
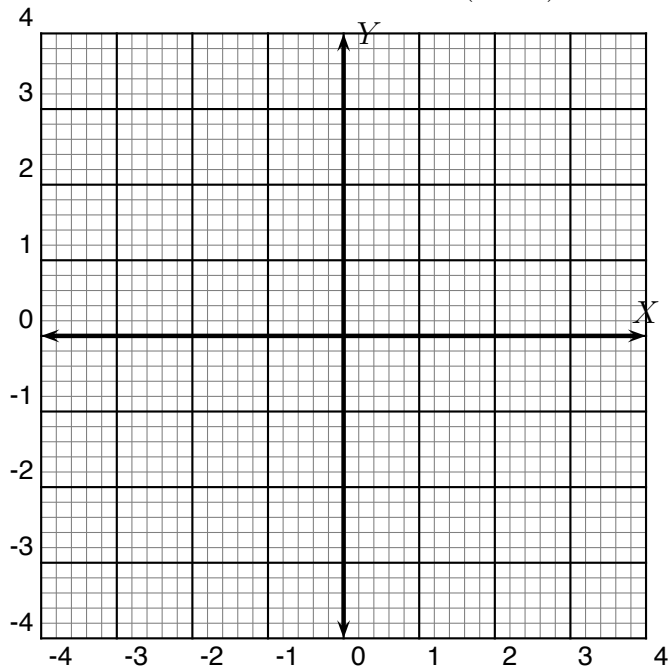

(b)  $f(x) = 3x + 5$  and  $h(x) = \frac{(3x + 5)(x + 2)}{(x + 2)}$

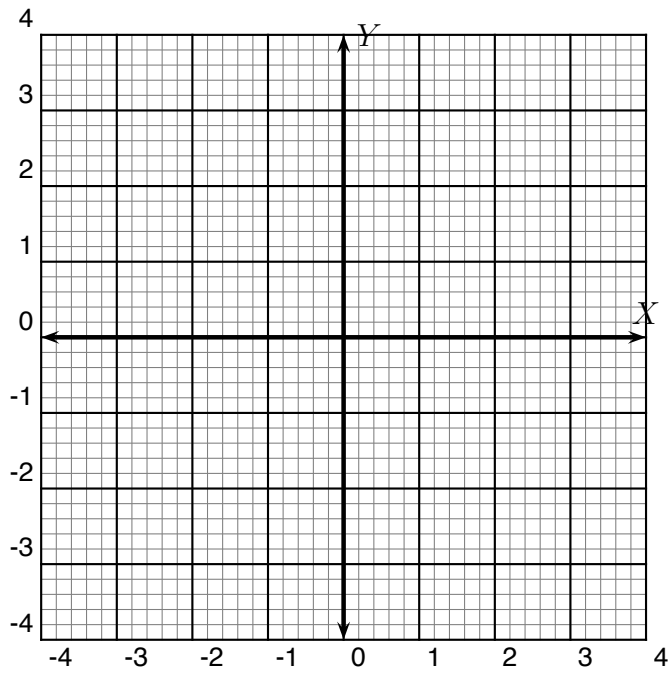
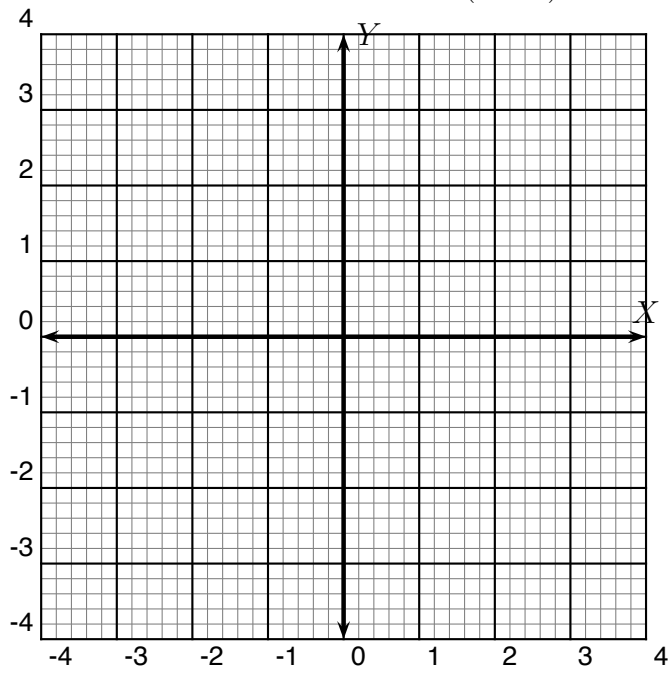

- (5) • Indicate the  $x$  values for which the function is undefined.  
• What is the domain of the function?  
• Graph the function.

(a)  $f(x) = \frac{x^2 - 7x - 18}{x + 2}$

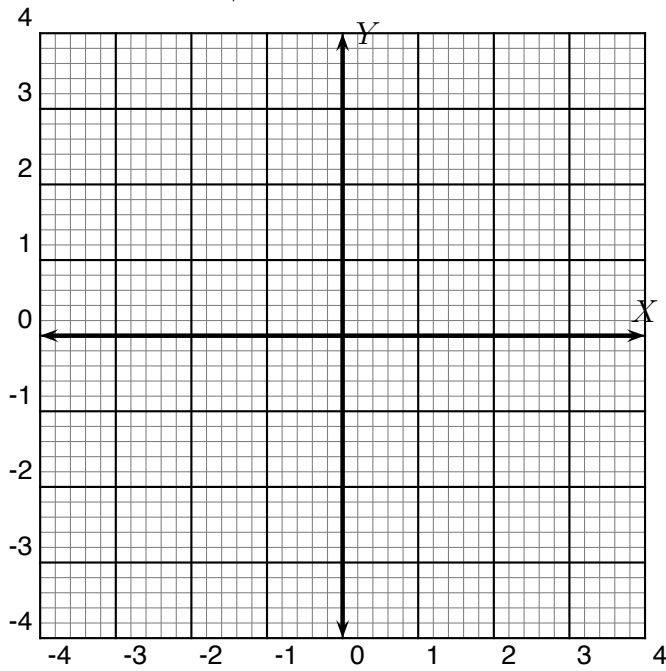

(b)  $f(x) = \frac{x^3 - 16x}{x^2 - 4x}$

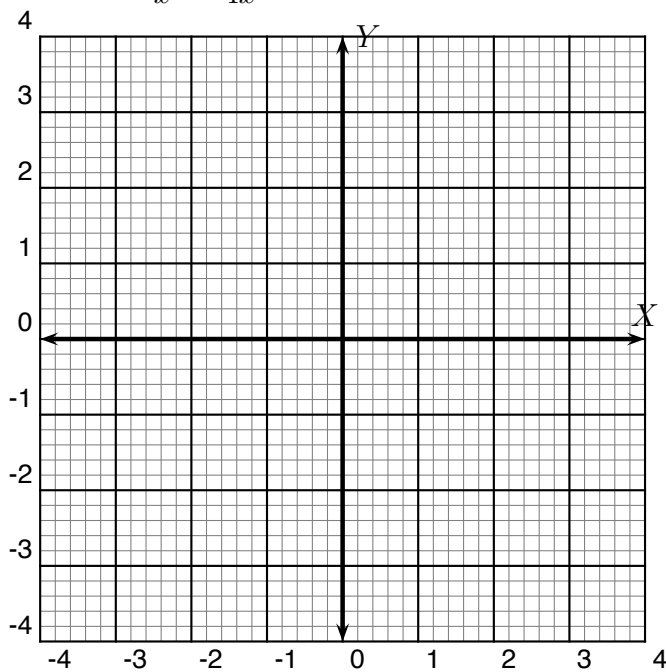

$$(c) f(x) = \frac{6x^3 + 29x^2 + 35x}{3x^2 + 7x}$$

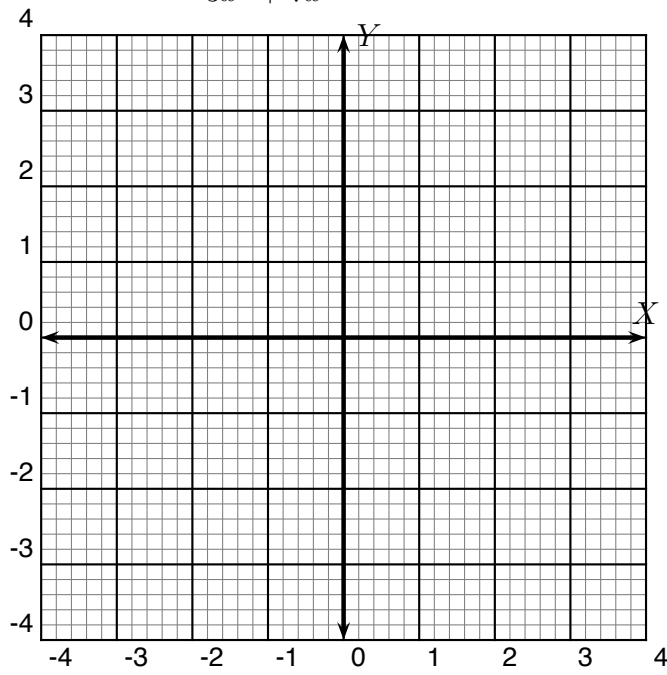

$$(d) f(x) = \frac{2x^2 - 11x + 15}{x - 3}$$

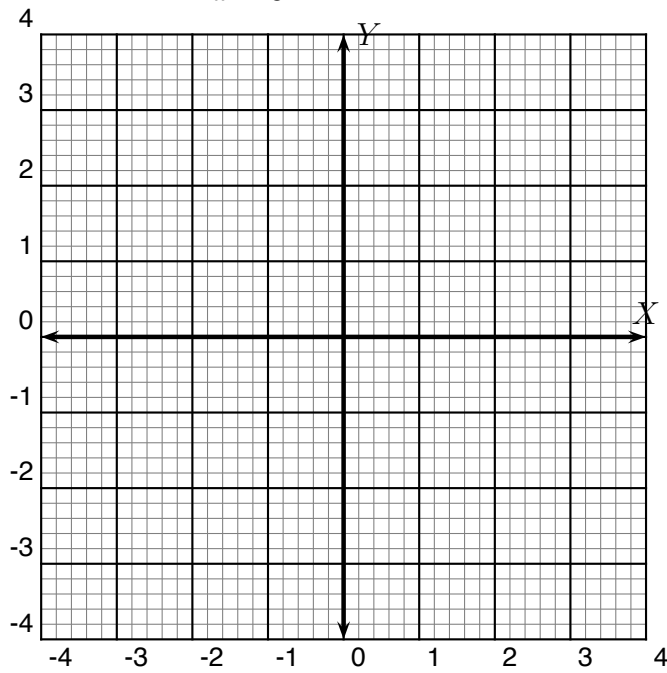

## 9. MULTIPLICATION AND DIVISION OF RATIONAL EXPRESSIONS

(1) Multiply:

(a)  $\frac{1}{3} \times \frac{2}{5}$

(b)  $\frac{1}{3} \times \frac{6}{5}$

(c)  $\frac{10}{3} \times \frac{12}{15}$

(d)  $\frac{10x^3y^2}{3z^2w} \times \frac{12z^8w^9}{15xy}$

(e)  $\frac{10x(x-3)(x-2)}{3(2x+1)(x+3)} \times \frac{12(x+3)}{15x(x-2)}$

(f)  $\frac{10x^3 - 50x^2 + 60x}{6x^2 + 19x + 3} \times \frac{12x + 36}{15x^2 - 30x}$

(g)  $\frac{6a^3b^{12}}{7c^4d^6} \times \frac{14c^5e}{3a^{20}b}$

(h)  $\frac{6(a-2)^3(b+2)^{12}}{7(c-2)^4(d+5)^6} \times \frac{14(c-2)^5(e+1)}{3(a-2)^{20}(b+2)}$

(i)  $\frac{x^2 + 7x + 10}{x^2 + 5x} \times \frac{2x}{x^2 - 4}$

(j)  $\frac{b^2 + 2b - 8}{b^2 - 2b} \times \frac{b^2 - 16}{4b}$

(k)  $\frac{a^3 - b^3}{a^3 + b^3} \times \frac{a^2 - ab + b^2}{a^2 - b^2}$

(l)  $\frac{x^3 - 8}{x^3 + 8} \times \frac{x^2 + 4x + 4}{x^4 - 16}$

(m)  $\frac{8x^2 + 22x + 15}{6x^2 - 5x - 25} \times \frac{15x^2 + 28x + 5}{8x^2 + 6x - 5}$

(n)  $\frac{3x^2 - 14x + 8}{35x^2 + 16x - 3} \times \frac{35x^2 + 31x + 6}{6x^2 + 5x - 6}$

(o)  $\frac{6px + 9xq + 2yp + 3yq}{6px - 2xq + 15yp - 5yq} \times \frac{8px - 2xq + 20yp - 5yq}{2px - 10py + 3qx - 15qy}$

(2) Let  $f(x) = \frac{x^2 + 7x + 10}{x^2 + 5x}$ ,  $g(x) = \frac{2x}{x^2 - 4}$  and  $h(x) = f(x) \cdot g(x)$ . Evaluate  $f(0) \cdot g(0)$ ,  $h(0)$ ,  $f(1) \cdot g(1)$ ,  $h(1)$ ,  $f(-2) \cdot g(-2)$  and  $h(-2)$ . For what values of  $x$  is  $h(x)$  undefined?

(3) Divide:

(a)  $\frac{1}{3} \div \frac{2}{5}$

(b)  $\frac{1}{3} \div \frac{5}{6}$

(c)  $\frac{10}{3} \div \frac{15}{12}$

(d)  $\frac{10x^3y^2}{3z^2w} \div \frac{15xy}{12z^8w^9}$

(e)  $\frac{12(x+3)}{15x(x-2)} \div \frac{3(2x+1)(x+3)}{10x(x-3)(x-2)}$

(f)  $\frac{6x^2 + 19x + 3}{10x^3 - 50x^2 + 60x} \div \frac{12x + 36}{15x^2 - 30x}$

(g)  $\frac{7c^4d^6}{6a^3b^{12}} \div \frac{14c^5e}{3a^{20}b}$

(h)  $\frac{7(c-2)^4(d+5)^6}{6(a-2)^3(b+2)^{12}} \div \frac{14(c-2)^5(e+1)}{3(a-2)^{20}(b+2)}$

(i)  $\frac{2x}{x^2 - 4} \div \frac{x^2 + 5x}{x^2 + 7x + 10}$

(j)  $\frac{b^2 + 2b - 8}{b^2 - 2b} \div \frac{4b}{b^2 - 16}$

(k)  $\frac{8x^2 + 22x + 15}{6x^2 - 5x - 25} \div \frac{8x^2 + 6x - 5}{15x^2 + 28x + 5}$

(l)  $\frac{3x^2 - 14x + 8}{35x^2 + 16x - 3} \div \frac{6x^2 + 5x - 6}{35x^2 + 31x + 6}$

(m)  $\frac{6px - 2xq + 15yp - 5yq}{6px + 9xq + 2yp + 3yq} \div \frac{8px - 2xq + 20yp - 5yq}{2px - 10py + 3qx - 15qy}$

(n)  $\frac{a^3 + b^3}{a^3 - b^3} \div \frac{a^2 - ab + b^2}{a^2 - b^2}$

(o)  $\frac{x^2 + 4x + 4}{x^4 - 16} \div \frac{x^3 + 8}{x^3 - 8}$

(4) Let  $f(x) = \frac{2x}{x^2 - 4}$ ,  $g(x) = \frac{x^2 + 5x}{x^2 + 7x + 10}$ , and  $h(x) = \frac{f(x)}{g(x)}$ . Evaluate  $\frac{f(0)}{g(0)}$ ,  $h(0)$ ,  $\frac{f(1)}{g(1)}$ ,  $h(1)$ ,  $\frac{f(-2)}{g(-2)}$  and  $h(-2)$ . For what values of  $x$  is  $h(x)$  undefined?



## 10. ADDITION AND SUBTRACTION OF RATIONAL EXPRESSIONS

(1) Find the Least Common Denominator (LCD) and perform the following additions:

(a)  $\frac{1}{3} + \frac{2}{5}$

(b)  $\frac{1}{3} + \frac{5}{6}$

(c)  $\frac{10}{3} + \frac{15}{12}$

(d)  $\frac{10x^3y^2}{3z^2w^9} + \frac{15xy}{12z^8w}$

(e)  $\frac{7c^4d^6}{6a^3b^{12}} + \frac{14c^5e}{3a^{20}b}$

(f)  $\frac{7(c-2)^4(d+5)^6}{6(a-2)^3(b+2)^{12}} + \frac{14(c-2)^5(e+1)}{3(a-2)^{20}(b+2)}$

(g)  $\frac{2x}{x^2-4} + \frac{5x}{x^2+7x+10}$

(h)  $\frac{8}{b^2-2b} + \frac{4b}{b^2-4}$

(i)  $\frac{3}{a^2-4a-12} + \frac{4}{a^2+10a+16}$

(j)  $\frac{12(x+3)}{15x(x-2)} + \frac{3(2x+1)(x+3)}{10x(x-3)(x-2)}$

(k)  $\frac{3a}{a+3} + \frac{a^2+5a}{a^2-9}$

$$(l) \frac{4}{x^2 - 16} + \frac{3x}{x^2 - x - 12}$$

$$(m) \frac{6}{2x^2 + 9x + 4} + \frac{3x}{2x^2 - 7x - 4}$$

$$(n) \frac{4x}{3x^2 - x - 2} + \frac{3}{3x^2 - 5x + 2}$$

$$(o) \frac{4}{a - b} + \frac{2}{b - a}$$

$$(p) \frac{3x}{5x - 4} + \frac{2}{4 - 5x}$$

$$(q) \frac{6x^2 + 19x + 3}{10x^3 - 50x^2 + 60x} + \frac{12x + 36}{15x^2 - 30x}$$

$$(r) \frac{6x^2 + 19x + 15}{6x^2 - 5x - 25} + \frac{20x^2 + 29x + 5}{8x^2 + 6x - 5}$$

$$(s) \frac{3x^2 - 14x + 8}{35x^2 + 16x - 3} + \frac{6x^2 + 5x - 6}{35x^2 + 31x + 6}$$

$$(t) \frac{6px - 2xq + 15yp - 5yq}{6px + 9xq + 2yp + 3yq} + \frac{8px - 2xq + 20yp - 5yq}{2px - 10py + 3qx - 15qy}$$

$$(u) \frac{x^2 + 4x + 4}{x^4 - 16} + \frac{x^3 + 8}{x^3 - 8}$$

$$(v) \frac{a^3 + b^3}{a^3 - b^3} + \frac{a^2 - ab + b^2}{a^2 - b^2}$$

- (2) Let  $f(x) = \frac{2x}{x^2 - 4}$ ,  $g(x) = \frac{x^2 + 5x}{x^2 + 7x + 10}$ , and  $h(x) = f(x) + g(x)$ . Evaluate  $f(0) + g(0)$ ,  $h(0)$ ,  $f(1) + g(1)$ ,  $h(1)$ ,  $f(-2) + g(-2)$  and  $h(-2)$ . For what values of  $x$  is  $h(x)$  undefined?

(3) Find the Least Common Denominator (LCD) and perform the following subtractions:

(a)  $\frac{1}{3} - \frac{2}{5}$

(b)  $\frac{1}{3} - \frac{5}{6}$

(c)  $\frac{10}{3} - \frac{15}{12}$

(d)  $\frac{10x^3y^2}{3z^2w^9} - \frac{15xy}{12z^8w}$

(e)  $\frac{7c^4d^6}{6a^3b^{12}} - \frac{14c^5e}{3a^{20}b}$

(f)  $\frac{7(c-2)^4(d+5)^6}{6(a-2)^3(b+2)^{12}} - \frac{14(c-2)^5(e+1)}{3(a-2)^{20}(b+2)}$

(g)  $\frac{2x}{x^2-4} - \frac{5x}{x^2+7x+10}$

(h)  $\frac{8}{b^2-2b} - \frac{4b}{b^2-4}$

(i)  $\frac{3}{a^2-4a-12} - \frac{4}{a^2+10a+16}$

(j)  $\frac{12(x+3)}{15x(x-2)} - \frac{3(2x+1)(x+3)}{10x(x-3)(x-2)}$

(k)  $\frac{3a}{a+3} - \frac{a^2+5a}{a^2-9}$

$$(l) \frac{4}{x^2 - 16} - \frac{3x}{x^2 - x - 12}$$

$$(m) \frac{6}{2x^2 + 9x + 4} - \frac{3x}{2x^2 - 7x - 4}$$

$$(n) \frac{4x}{3x^2 - x - 2} - \frac{3}{3x^2 - 5x + 2}$$

$$(o) \frac{4}{a - b} - \frac{2}{b - a}$$

$$(p) \frac{3x}{5x - 4} - \frac{2}{4 - 5x}$$

$$(q) \frac{6x^2 + 19x + 3}{10x^3 - 50x^2 + 60x} - \frac{12x + 36}{15x^2 - 30x}$$

$$(r) \frac{6x^2 + 19x + 15}{6x^2 - 5x - 25} - \frac{20x^2 + 29x + 5}{8x^2 + 6x - 5}$$

$$(s) \frac{3x^2 - 14x + 8}{35x^2 + 16x - 3} - \frac{6x^2 + 5x - 6}{35x^2 + 31x + 6}$$

$$(t) \frac{6px - 2xq + 15yp - 5yq}{6px + 9xq + 2yp + 3yq} - \frac{8px - 2xq + 20yp - 5yq}{2px - 10py + 3qx - 15qy}$$

$$(u) \frac{x^2 + 4x + 4}{x^4 - 16} - \frac{x^3 + 8}{x^3 - 8}$$

$$(v) \frac{a^3 + b^3}{a^3 - b^3} - \frac{a^2 - ab + b^2}{a^2 - b^2}$$

- (4) Let  $f(x) = \frac{2x}{x^2 - 4}$ ,  $g(x) = \frac{x^2 + 5x}{x^2 + 7x + 10}$ , and  $h(x) = f(x) - g(x)$ . Evaluate  $f(0) - g(0)$ ,  $h(0)$ ,  $f(1) - g(1)$ ,  $h(1)$ ,  $f(-2) - g(-2)$  and  $h(-2)$ . For what values of  $x$  is  $h(x)$  undefined?

(5) Evaluate each expression for the given variable value(s).

(a)  $1 + \frac{1}{x}; \quad x = 1, 2, 0$

(b)  $1 + \frac{1}{1 - \frac{1}{x}}; \quad x = 1, 2, 0$

(c)  $1 + \frac{1}{1 - \frac{1}{1 + \frac{1}{x}}}; \quad x = 1, 2, 0$

(d)  $1 + \frac{1}{1 - \frac{1}{1 + \frac{1}{1 + \frac{1}{x}}}}; \quad x = 1, 2, 0$

## 11. COMPLEX FRACTIONS

Perform the following operations:

$$(1) \frac{\frac{3}{5}}{\frac{10}{35}}$$

$$(2) \frac{2 + \frac{1}{3}}{2 - \frac{3}{5}}$$

$$(3) \frac{\frac{x^3}{12}}{\frac{x^5}{15}}$$

$$(4) \frac{\frac{x - 3y}{4y}}{\frac{x^2 - 3xy}{5xy}}$$

$$(5) \frac{\frac{5}{ab}}{\frac{2}{a} - \frac{3}{b}}$$

$$(6) \frac{\frac{x^2}{y^2} - 4}{\frac{x}{y} + 2}$$

$$(7) \frac{\frac{x^3}{y^3} - 8}{\frac{x}{y} - 2}$$



$$(8) \frac{\frac{2}{m-2} + \frac{1}{m-3}}{\frac{2}{m-2} - \frac{1}{m-3}}$$

$$(9) \frac{\frac{x+2}{x-2} + \frac{x+1}{x-3}}{\frac{x+2}{x-2} - \frac{x+1}{x-3}}$$

$$(10) 1 + \frac{1}{1 + \frac{1}{1 + \frac{1}{1 + \frac{1}{x}}}}$$

## 12. SOLVING RATIONAL EQUATIONS

## Review on similar triangles

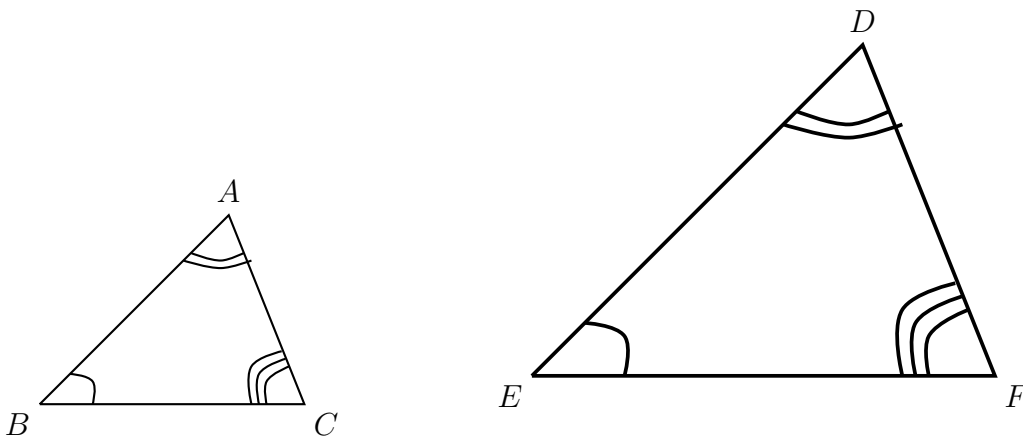

**Definition.**  $\triangle ABC$  is **similar** to  $\triangle DEF$ , written  $\triangle ABC \sim \triangle DEF$ , if and only if,  $\angle A \cong \angle D$ ,  $\angle B \cong \angle E$ ,  $\angle C \cong \angle F$ , and  $\frac{DE}{AB} = \frac{DF}{AC} = \frac{EF}{BC}$ . The ratio of the corresponding side lengths is called the **scale factor**.

Two triangles are similar if they have the same shape.

**Theorem.** If two angles of one triangle are congruent, respectively, to two angles of a second triangle, then the two triangles are similar.

- (1) Assume that in the following figures, the triangles are similar. Find the measures of the sides labeled  $x$ .

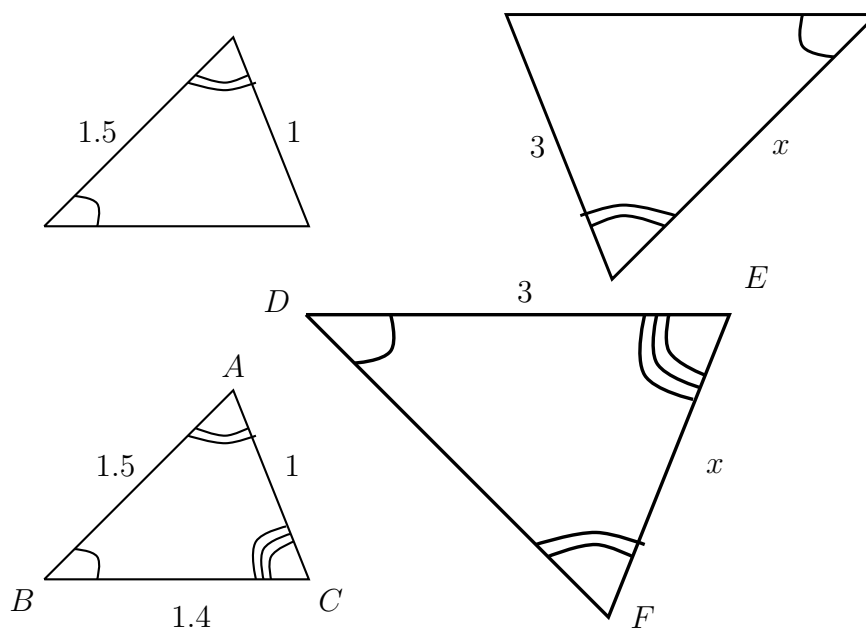

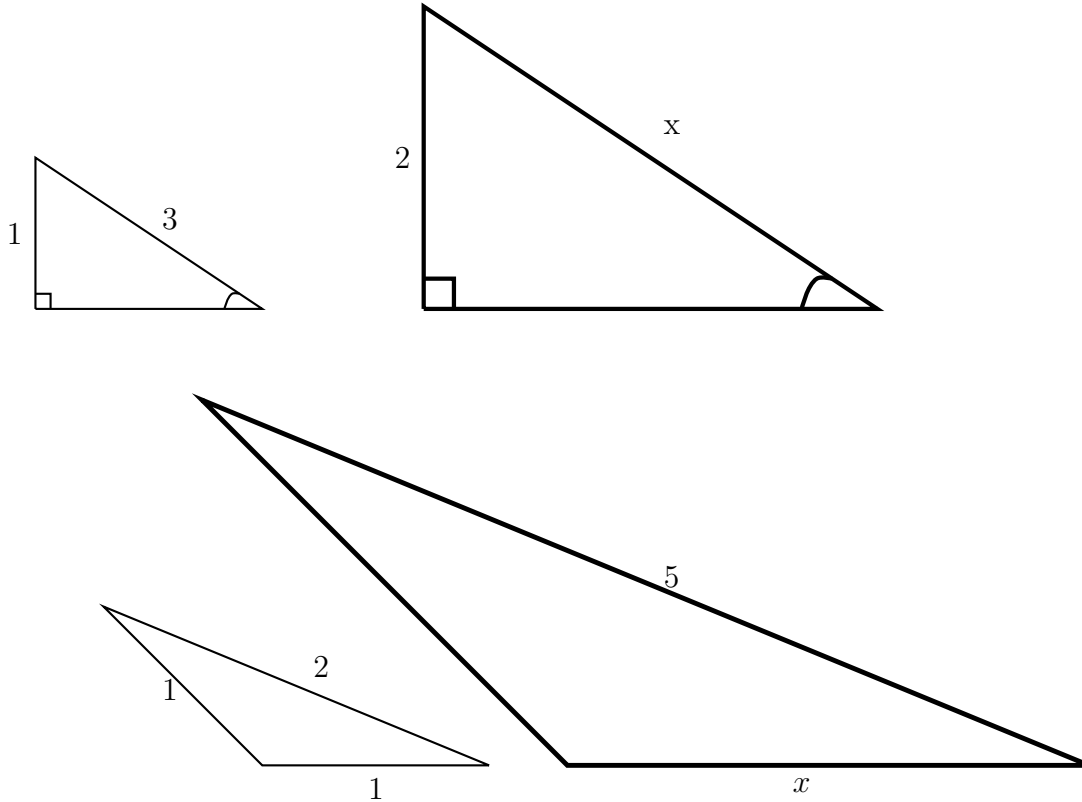

**End of the review on similar triangles.**

(1) Solve

(a)  $\frac{x}{12} - \frac{2}{3} = \frac{x}{6} + \frac{3}{4}$

(b)  $\frac{7}{6x} - \frac{1}{3} = \frac{1}{2x}$

(c)  $\frac{5}{x-2} = \frac{4}{x+1}$

(d)  $\frac{6}{x} + 3 = \frac{3x}{x+1}$

$$(e) \frac{10}{2x+6} + \frac{2}{x+3} = \frac{1}{2}$$

$$(f) \frac{x+1}{x-2} - \frac{x+3}{x} = \frac{6}{x^2-2x}$$

$$(g) \frac{2}{x-2} = \frac{3}{x+2} + \frac{x}{x^2-4}$$

$$(h) \frac{3}{x-4} - \frac{4}{x^2-3x-4} = \frac{1}{x+1}$$

$$(i) \frac{x}{x-4} + 3 = \frac{4}{x-4}$$

$$(j) \frac{3x}{x-1} = \frac{2}{x-2} - \frac{2}{x^2-3x+2}$$

$$(k) \frac{x^2}{3x^2+13x-10} - \frac{2}{x+5} = \frac{x-6}{3x-2}$$

$$(l) \frac{1}{x-2} + \frac{1}{x^2+2x+4} = \frac{9x+18}{x^3-8}$$

- (2) Assume the two triangles are similar. Find the indicated sides.

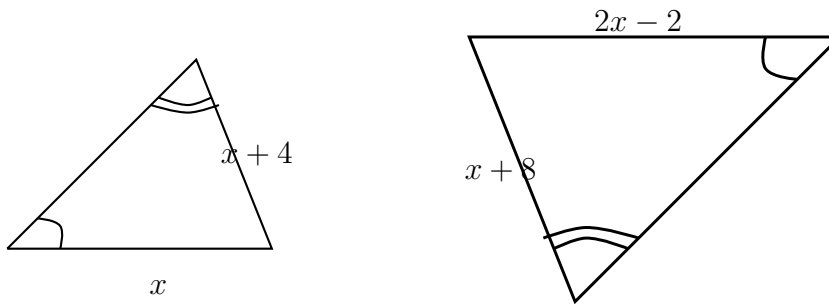

- (3) Solve each equation for the indicated variable.

(a)  $\frac{1}{x} = \frac{2}{a} + \frac{3}{b}$  for  $a$ .

(b)  $y = \frac{2x - 5}{3x + 2}$  for  $x$

- (4) The quotient of the difference between a number and 5, and the number itself is six times the difference between the number and 2. Find the number.

- (5) A small jet has an airspeed (the rate in still air) of 300 mi/h. During one day's flights, the pilot noted that the plane could fly 85 mi with a tailwind in the same time it took to fly 65 mi against the same wind. What was the rate of the wind?

## 13. EXPONENTIAL FUNCTIONS

**The Exponential function:**

$$f(x) = b^x \text{ for } b > 0 \text{ and } b \neq 1.$$

Here,  $b$  is the **base** of the exponential function.

What happens when  $b = 1$ ? What is its graph?

What happens when  $b < 0$ ? What about  $b = 0$ ?

Graph the following exponential functions. Provide at least 5 points. What are its  $X$  or  $Y$  intercepts if any. Give its domain and range. Sketch the horizontal asymptote as a dotted line, and give its equation.

(1)  $f(x) = 2^x$

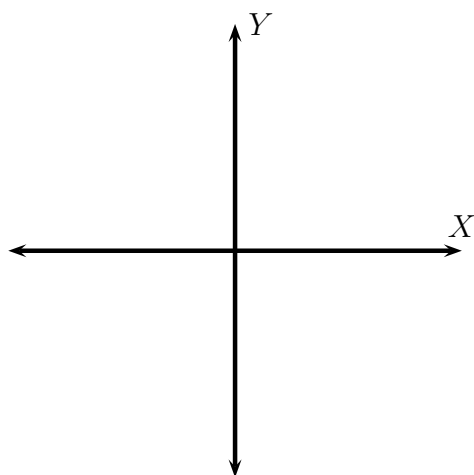

(2)  $f(x) = 3^x$

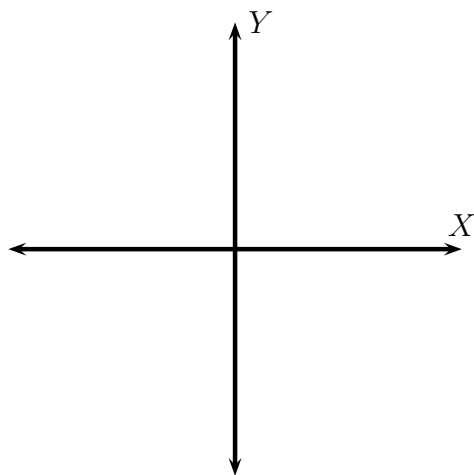

$$(3) f(x) = \left(\frac{1}{2}\right)^x$$

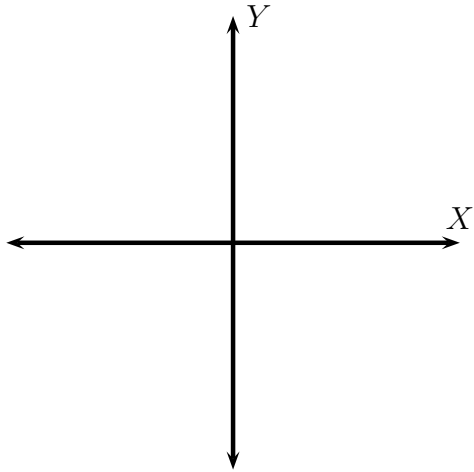

$$(4) f(x) = \left(\frac{1}{3}\right)^x$$

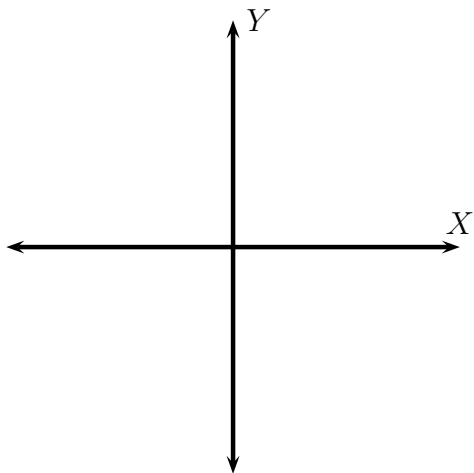

$$(5) f(x) = 2^x + 1$$

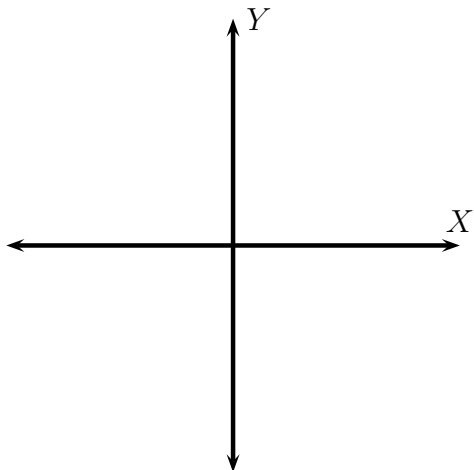

$$(6) f(x) = \left(\frac{1}{3}\right)^x - 2$$

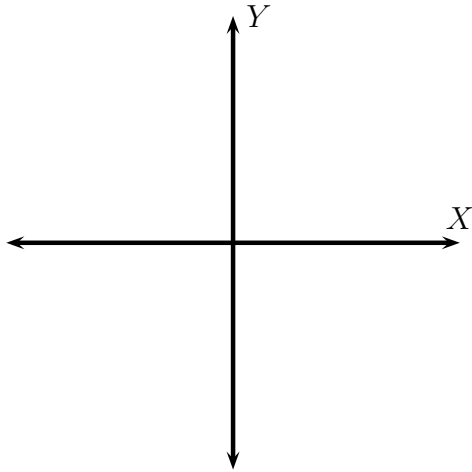

$$(7) f(x) = 3 \cdot 2^x$$

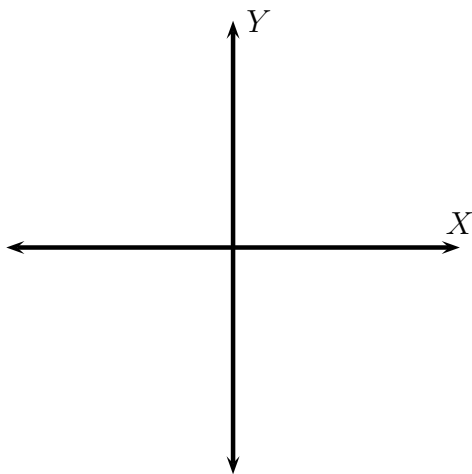

$$(8) f(x) = 2^{x+1} = 2 \cdot 2^x$$

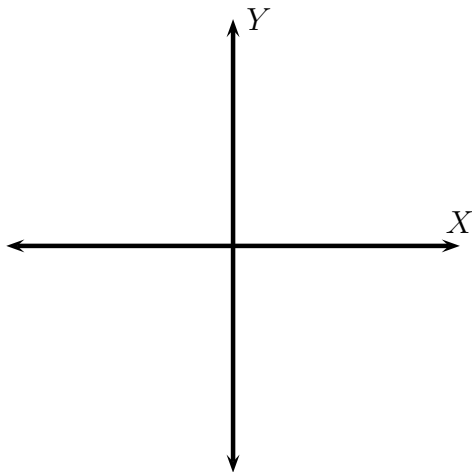



$$(9) f(x) = \left(\frac{5}{2}\right)^x$$

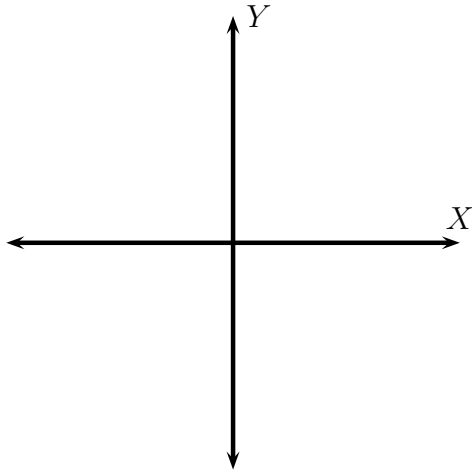

$$(10) f(x) = \left(\frac{2}{5}\right)^x$$

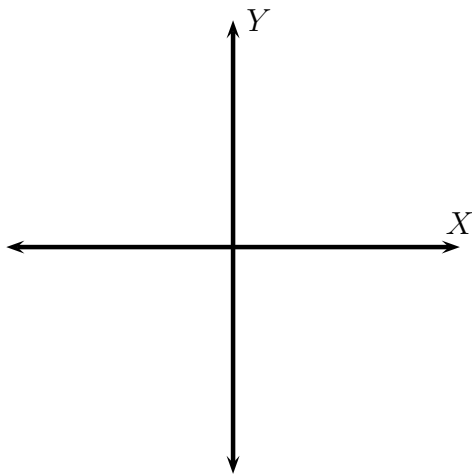

- (11) Using an example discuss the graphs of  $f(x) = b^x$  and  $g(x) = b^{-x}$  when  $b > 1$ . Your discussion should include concepts of *increasing/decreasing*, *horizontal asymptotes*, and *symmetry of the two graphs*.

(12) Discuss the graphs of  $f(x) = b^x$  and  $g(x) = c^x$  when  $b > c > 1$ . Your discussion should include concepts of *steepness*, and *horizontal asymptotes*.

(13) Discuss the graphs of  $f(x) = b^x$  and  $g(x) = c^x$  when  $0 < b < c < 1$ . Your discussion should include concepts of *steepness*, and *horizontal asymptotes*.

Solve for  $x$

(1)  $2^x = 256$

(2)  $3^x = 81$

(3)  $4^{x-1} = 64$

(4)  $5^{x+1} = \frac{1}{25}$

(5)  $6^{x-3} = \frac{1}{36}$

## 14. LOGARITHMIC FUNCTIONS

**The Logarithmic function** is the **inverse** function of the exponential function.

For  $b > 0, b \neq 1$ ,

$$\log_b x = y \text{ if and only if } b^y = x.$$

What values of  $x$  is  $\log_b x$  undefined? When is  $\log_b x = 0$ ?

(1) Convert each statement to a radical equation.

(a)  $2^4 = 16$ .

(b)  $3^5 = 243$ .

(c)  $\left(\frac{2}{3}\right)^4 = \frac{16}{81}$ .

(2) Convert each statement to a logarithmic equation. How is this form different from the radical form?.

(a)  $2^4 = 16$ .

(b)  $3^5 = 243$ .

(c)  $\left(\frac{2}{3}\right)^4 = \frac{16}{81}$ .

(3) Convert each statement to exponential form:

(a)  $\log_{10} 1000 = 3$ .

(b)  $\log_{\frac{1}{3}} 9 = -2$ .

(c)  $\log_{25} 5 = \frac{1}{2}$ .

(d)  $\log_5 25 = 2$ .

(4) Graph (plot at least five points). What are the  $X$  or  $Y$  intercepts if any. Give the range and domain of the graph. Sketch the relevant asymptote as a dotted line and give its equation.

(a)  $f(x) = 2^x$  and  $g(x) = \log_2 x$

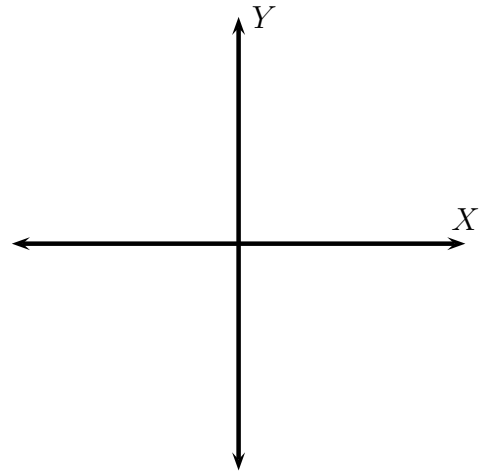
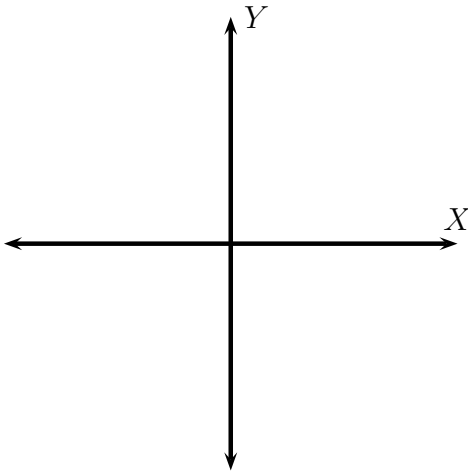

(b)  $f(x) = 3^x$  and  $g(x) = \log_3 x$

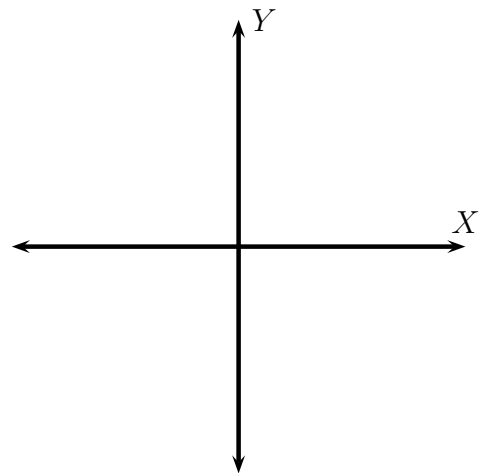
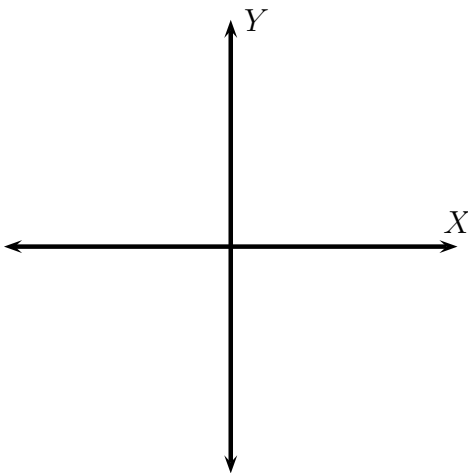

(c)  $f(x) = 10^x$  and  $g(x) = \log_{10} x$

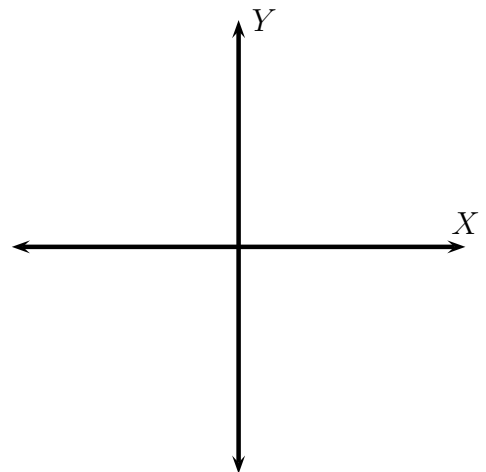
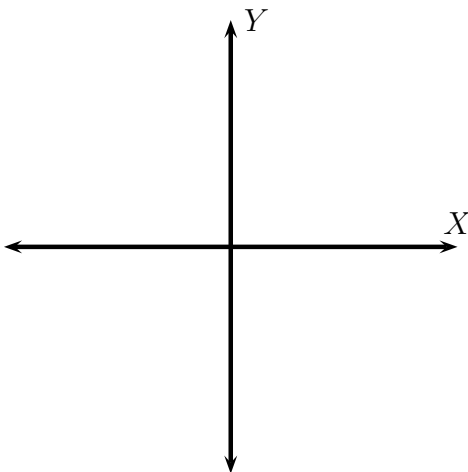

(d)  $f(x) = \log_3(x - 1)$

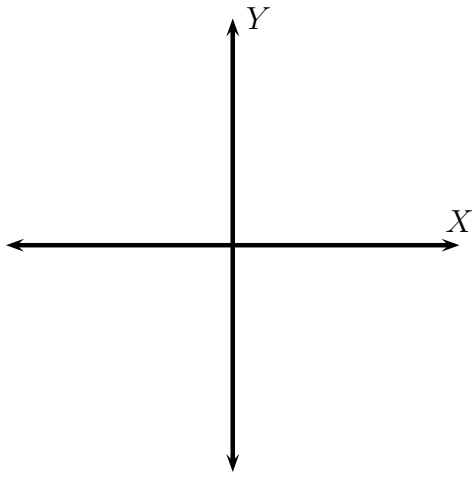

(e)  $f(x) = \log_3 x + 2$

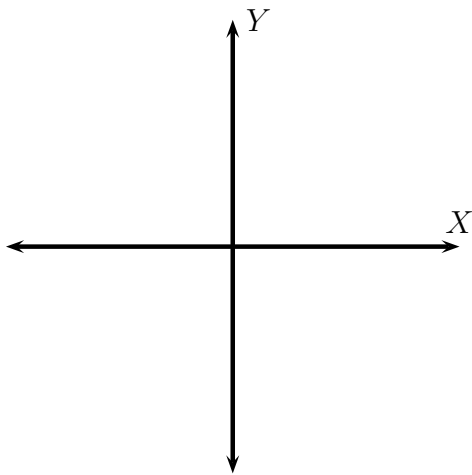

(f)  $f(x) = \log_2(x + 1)$

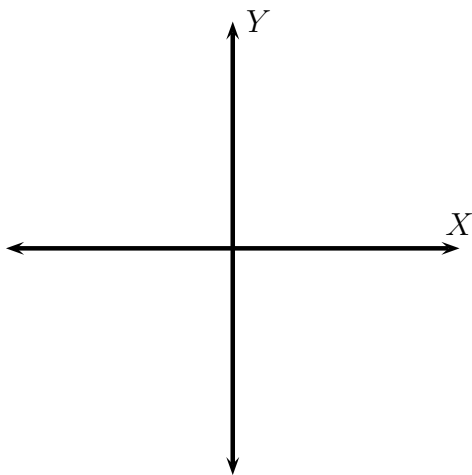

(g)  $f(x) = \log_2 x - 1$

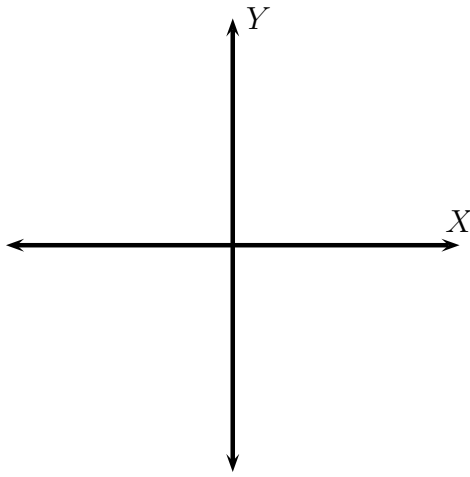

(5) Solve for  $x$ :

(a)  $\log_4 64 = x$

(b)  $\log_5 x = 1$

(c)  $\log_2 x = 0$

(d)  $\log_3 81 = x$

(e)  $\log_2 \frac{1}{32} = x$

(f)  $\log_{36} \frac{1}{6} = x$

(g)  $\log_x 12 = \frac{1}{2}$

(h)  $\log_x 12 = 2$

(i)  $\log_x 9 = 2$

(j)  $\log_x 4 = 16$

$$(k) \log_2(x - 4) = 4$$

$$(l) \log_3 243 = (2x + 3)$$

$$(m) \log_{125} x = \frac{1}{3}$$

$$(n) \log_5 x = \frac{1}{3}$$

$$(o) \log_{10} x = 10$$

$$(p) \log_5(x^2 - 5x + 1) = 2$$

$$(q) \log_3(6x^2 - 5x + 23) = 3$$

## 15. THE TRIGONOMETRIC RATIOS

In this section we will start the study of **trigonometric functions**. We first need the following two important calculations.

- (1) Find the lengths of the legs of an isosceles right triangle with hypotenuse of length 1.

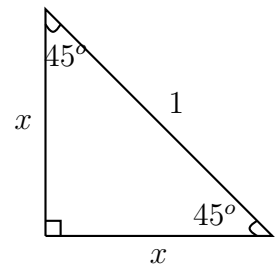

- (2) Find the lengths of the legs of a  $30^\circ - 60^\circ - 90^\circ$  triangle with hypotenuse of length 1.

$\triangle ABC$  is a  $30^\circ - 60^\circ - 90^\circ$  triangle.  
 $\triangle ADC$  is a mirror image of  $\triangle ABC$ .  
 What kind of triangle is  $\triangle ABD$ ? Explain.

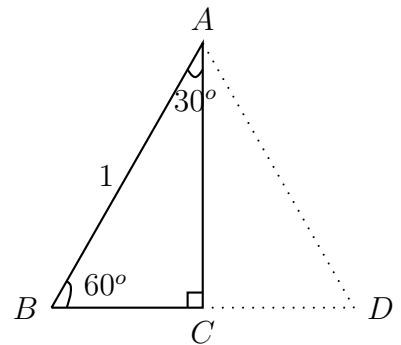

What is the length of segment  $BC$ ?

What is the length of segment  $AC$ ?

- (3) The lengths of the legs of an isosceles right triangle with hypotenuse of length 1 are \_\_\_\_\_ and \_\_\_\_\_.
- (4) The lengths of the legs of a  $30^\circ - 60^\circ - 90^\circ$  triangle with hypotenuse of length 1 are \_\_\_\_\_ and \_\_\_\_\_.



**trigonometric functions.** Given is a right triangle  $\triangle ABC$  with side lengths  $a, b, c$ . Note the naming scheme: The side opposite  $\angle A$  has length  $a$ , the side opposite  $\angle B$  has length  $b$ , and the side opposite  $\angle C$  (the hypotenuse) has length  $c$ . For any acute angle,

$$\text{Cosine of the angle} = \frac{\text{length of its adjacent side}}{\text{length of the hypotenuse}}$$

$$\text{Sine of the angle} = \frac{\text{length of its opposite side}}{\text{length of the hypotenuse}}$$

$$\text{Tangent of the angle} = \frac{\text{length of its opposite side}}{\text{length of its adjacent side}}$$

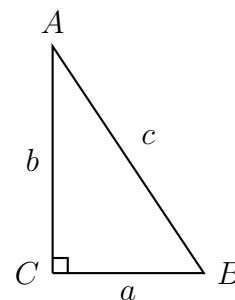

Notations and more trigonometric functions: For an acute angle  $A$ ,

$$\text{Sine of angle } A = \sin(A)$$

$$\text{Cosine of angle } A = \cos(A)$$

$$\text{Tangent of angle } A = \tan(A) = \left( \frac{\sin(A)}{\cos(A)} \right)$$

$$\text{Cosecant of angle } A = \csc(A) = \left( \frac{1}{\sin(A)} \right)$$

$$\text{Secant of angle } A = \sec(A) = \left( \frac{1}{\cos(A)} \right)$$

$$\text{Cotangent of angle } A = \cot(A) = \left( \frac{\cos(A)}{\sin(A)} \right) = \left( \frac{1}{\tan(A)} \right)$$

Use the figure above to fill in the following table:

| Function         | $A$ | $B$ |
|------------------|-----|-----|
| <i>Sine</i>      |     |     |
| <i>Cosine</i>    |     |     |
| <i>Tangent</i>   |     |     |
| <i>Cosecant</i>  |     |     |
| <i>Secant</i>    |     |     |
| <i>Cotangent</i> |     |     |

Use your results from the  $45^\circ - 45^\circ - 90^\circ$  and  $30^\circ - 60^\circ - 90^\circ$  triangles to fill in the following table:

| Function         | $30^\circ$ | $45^\circ$ | $60^\circ$ |
|------------------|------------|------------|------------|
| <i>Sine</i>      |            |            |            |
| <i>Cosine</i>    |            |            |            |
| <i>Tangent</i>   |            |            |            |
| <i>Cosecant</i>  |            |            |            |
| <i>Secant</i>    |            |            |            |
| <i>Cotangent</i> |            |            |            |

Fill in the table for the given right triangle:

- Triangle 1.

| Function         | $A$ | $B$ |
|------------------|-----|-----|
| <i>Sine</i>      |     |     |
| <i>Cosine</i>    |     |     |
| <i>Tangent</i>   |     |     |
| <i>Cosecant</i>  |     |     |
| <i>Secant</i>    |     |     |
| <i>Cotangent</i> |     |     |

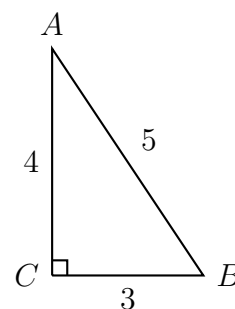

- Triangle 2.

| Function         | $A$ | $B$ |
|------------------|-----|-----|
| <i>Sine</i>      |     |     |
| <i>Cosine</i>    |     |     |
| <i>Tangent</i>   |     |     |
| <i>Cosecant</i>  |     |     |
| <i>Secant</i>    |     |     |
| <i>Cotangent</i> |     |     |

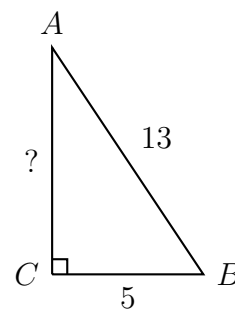

- Triangle 3.

| Function         | $A$ | $B$ |
|------------------|-----|-----|
| <i>Sine</i>      |     |     |
| <i>Cosine</i>    |     |     |
| <i>Tangent</i>   |     |     |
| <i>Cosecant</i>  |     |     |
| <i>Secant</i>    |     |     |
| <i>Cotangent</i> |     |     |

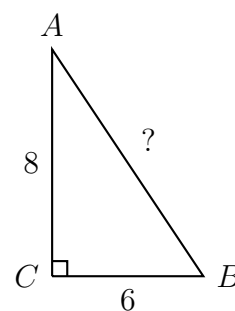

- Triangle 4.

| Function         | $A$ | $B$ |
|------------------|-----|-----|
| <i>Sine</i>      |     |     |
| <i>Cosine</i>    |     |     |
| <i>Tangent</i>   |     |     |
| <i>Cosecant</i>  |     |     |
| <i>Secant</i>    |     |     |
| <i>Cotangent</i> |     |     |

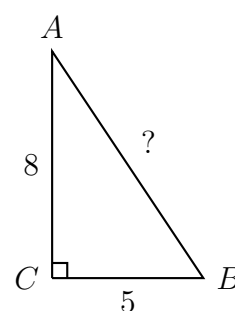

- Triangle 5.

| Function         | $A$ | $B$ |
|------------------|-----|-----|
| <i>Sine</i>      |     |     |
| <i>Cosine</i>    |     |     |
| <i>Tangent</i>   |     |     |
| <i>Cosecant</i>  |     |     |
| <i>Secant</i>    |     |     |
| <i>Cotangent</i> |     |     |

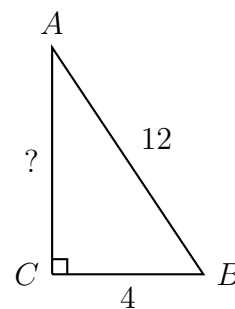

- Triangle 6.

| Function         | $A$ | $B$ |
|------------------|-----|-----|
| <i>Sine</i>      |     |     |
| <i>Cosine</i>    |     |     |
| <i>Tangent</i>   |     |     |
| <i>Cosecant</i>  |     |     |
| <i>Secant</i>    |     |     |
| <i>Cotangent</i> |     |     |

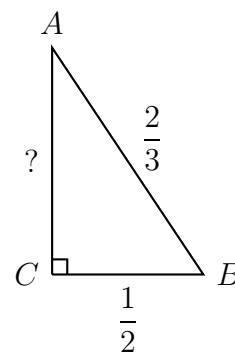

- Triangle 7.

| Function         | $A$ | $B$ |
|------------------|-----|-----|
| <i>Sine</i>      |     |     |
| <i>Cosine</i>    |     |     |
| <i>Tangent</i>   |     |     |
| <i>Cosecant</i>  |     |     |
| <i>Secant</i>    |     |     |
| <i>Cotangent</i> |     |     |

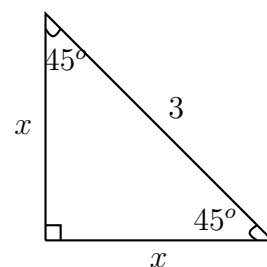

Does this table look familiar?

- Triangle 8.

| Function         | $A$ | $B$ |
|------------------|-----|-----|
| <i>Sine</i>      |     |     |
| <i>Cosine</i>    |     |     |
| <i>Tangent</i>   |     |     |
| <i>Cosecant</i>  |     |     |
| <i>Secant</i>    |     |     |
| <i>Cotangent</i> |     |     |

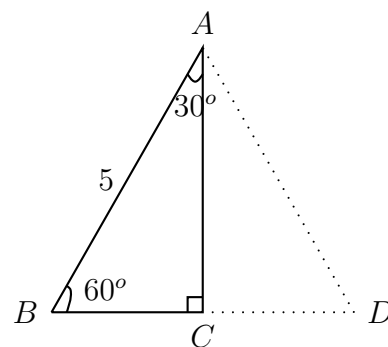

Does this table look familiar?

Complete the following tables (Write trigonometric expressions for angles.):

| Function/Angle   |               |               |               |               |               |               |
|------------------|---------------|---------------|---------------|---------------|---------------|---------------|
| <i>Sine</i>      | $\frac{3}{4}$ |               |               |               |               |               |
| <i>Cosine</i>    |               | $\frac{2}{3}$ |               |               |               |               |
| <i>Tangent</i>   |               |               | $\frac{3}{2}$ |               |               |               |
| <i>Cosecant</i>  |               |               |               | $\frac{5}{4}$ |               |               |
| <i>Secant</i>    |               |               |               |               | $\frac{7}{6}$ |               |
| <i>Cotangent</i> |               |               |               |               |               | $\frac{7}{8}$ |

| Function/Angle   |               |                      |   |               |               |                |
|------------------|---------------|----------------------|---|---------------|---------------|----------------|
| <i>Sine</i>      | $\frac{1}{2}$ |                      |   |               |               |                |
| <i>Cosine</i>    |               | $\frac{\sqrt{3}}{2}$ |   |               |               |                |
| <i>Tangent</i>   |               |                      | 1 |               |               |                |
| <i>Cosecant</i>  |               |                      |   | $\frac{7}{4}$ |               |                |
| <i>Secant</i>    |               |                      |   |               | $\frac{9}{7}$ |                |
| <i>Cotangent</i> |               |                      |   |               |               | $\frac{11}{8}$ |

## 16. APPLYING RIGHT TRIANGLES

In what follows, “Solve each right triangle” means find the measures of all the interior angles and the lengths of all the sides of the right triangle. Leave your answers in trigonometric expressions whenever relevant.

(1) Solve each right  $\triangle ABC$  using the given information. In each case  $m\angle C = 90^\circ$ .

(a)  $m\angle A = 82^\circ, b = 72.35$ .

(b)  $m\angle A = 43^\circ, c = 33.45$ .

(c)  $m\angle A = 73^\circ, a = 123.51$ .

(d)  $m\angle B = 56^\circ, b = 87.23$ .

(e)  $m\angle B = 23^\circ, b = 153.25$ .

(f)  $m\angle B = 67^\circ, b = 48.93$ .

(g)  $a = 58.34, b = 73.94$

(h)  $a = 23.15, c = 31.24$

(i)  $b = 35.32, c = 43.12$

- (2) Find the distance  $d$  across a river if  $e = 212$  ft. and  $m\angle D = 79^\circ$ .

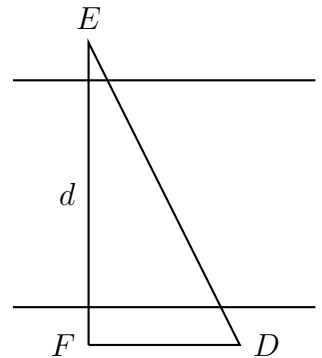

- (3) The angle of elevation of the top of a fir tree is  $68^\circ$  from an observation point 70 ft. from the base of the tree. Find the height of the tree.
- (4) A 35 ft. pole casts a shadow 10 ft. long. Find the angle of elevation of the sun.

(5) Find the area of each right  $\triangle ABC$ :

(a)  $m\angle A = 34^\circ, b = 32.43$  ft.

(b)  $m\angle A = 71^\circ, a = 32.43$  ft.

(c)  $m\angle A = 37^\circ, c = 49.73$  ft.

(d)  $m\angle B = 53^\circ, b = 32.43$  ft.

(e)  $m\angle B = 27^\circ, a = 32.43$  ft.

(f)  $m\angle B = 28^\circ, c = 49.73$  ft.

(6) Find the area of the regular polygon described here:

(a) Six sided polygon with length of each side 24 ft.

(b) Eight sided polygon with length of each side 42 ft.

(c) Twelve sided polygon with length of each side 20 ft.

## 17. THE TRIGONOMETRIC FUNCTIONS AND CARTESIAN COORDINATES

A point on the coordinate plane is determined by its  $x$  and  $y$  coordinates. These coordinates are called the **rectangular coordinates**.

Another way of describing a point on the coordinate plane is by using its **polar coordinates**,  $(r, \theta)$  for  $r > 0, 0 \leq \theta < 360^\circ$ .

Here,  $r$  is the distance between the point  $(x, y)$  and the point  $(0, 0)$ ;  $\theta$  is the angle subtended by the ray joining  $(0, 0)$  and  $(x, y)$  with the positive  $x$ -axis measured anticlockwise. By convention, the point  $(0, 0)$  in polar coordinates is also  $(0, 0)$ .

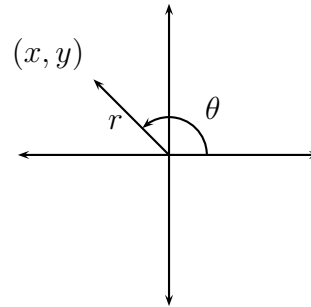

We say that an angle is in **standard position** if the angle is placed with its vertex at the origin and its initial side lying on the positive part of the  $x$ -axis.

- (1) Give a formula for  $r$  in terms of  $x$  and  $y$ .
  
- (2) Find the polar coordinates of the point with the given rectangular coordinates:
  - (a)  $(2, 0)$
  
  - (b)  $(2, 3)$
  
  - (c)  $(0, 4)$
  
  - (d)  $(-2, 5)$



(e)  $(-3, 0)$

(f)  $(-3, -5)$

(g)  $(0, -5)$

(h)  $(3, -5)$

(3) Find the rectangular coordinates of the point with the given polar coordinates:

(a)  $(2, 0^\circ)$

(b)  $(2, 30^\circ)$

(c)  $(3, 45^\circ)$

(d)  $(4, 60^\circ)$

(e)  $(2, 50^\circ)$

(f)  $(3, 90^\circ)$

(g)  $(4, 120^\circ)$

(h)  $(5, 135^\circ)$

(i)  $(2, 150^\circ)$

(j)  $(3, 160^\circ)$

(k)  $(4, 180^\circ)$

(l)  $(5, 210^\circ)$

(m)  $(6, 225^\circ)$

(n)  $(7, 240^\circ)$

(o)  $(2, 250^\circ)$

(p)  $(2, 270^\circ)$

(q)  $(2, 300^\circ)$

(r)  $(3, 315^\circ)$

(s)  $(4, 330^\circ)$

(t)  $(2, 340^\circ)$

- (4) In the previous lesson we defined trigonometric functions for acute angles. We are now ready to define trigonometric functions for all angles, keeping in mind that division by 0 is undefined.

Let  $(x, y)$  be the terminal point of the ray given by an angle  $\theta$  then

- $\sin(\theta) = \frac{y}{r}$
- $\cos(\theta) = \frac{x}{r}$
- $\tan(\theta) = \frac{\sin(\theta)}{\cos(\theta)} = \frac{y}{x}$
- $\csc(\theta) = \frac{1}{\sin(\theta)} = \frac{r}{y}$
- $\sec(\theta) = \frac{1}{\cos(\theta)} = \frac{r}{x}$
- $\cot(\theta) = \frac{1}{\tan(\theta)} = \frac{x}{y}$

- (5) Fill in the blanks:

|                |        |        |        |         |         |          |         |         |
|----------------|--------|--------|--------|---------|---------|----------|---------|---------|
| $(x, y)$       | (5, 0) | (2, 5) | (0, 3) | (-3, 5) | (-3, 0) | (-4, -5) | (0, -5) | (3, -5) |
| $r$            |        |        |        |         |         |          |         |         |
| $\sin(\theta)$ |        |        |        |         |         |          |         |         |
| $\cos(\theta)$ |        |        |        |         |         |          |         |         |
| $\tan(\theta)$ |        |        |        |         |         |          |         |         |
| $\csc(\theta)$ |        |        |        |         |         |          |         |         |
| $\sec(\theta)$ |        |        |        |         |         |          |         |         |
| $\cot(\theta)$ |        |        |        |         |         |          |         |         |

- (6) Fill in the blanks:

|                |           |            |            |            |            |             |             |             |             |
|----------------|-----------|------------|------------|------------|------------|-------------|-------------|-------------|-------------|
| $\theta$       | $0^\circ$ | $30^\circ$ | $45^\circ$ | $60^\circ$ | $90^\circ$ | $120^\circ$ | $135^\circ$ | $150^\circ$ | $180^\circ$ |
| $\sin(\theta)$ |           |            |            |            |            |             |             |             |             |
| $\cos(\theta)$ |           |            |            |            |            |             |             |             |             |
| $\tan(\theta)$ |           |            |            |            |            |             |             |             |             |
| $\csc(\theta)$ |           |            |            |            |            |             |             |             |             |
| $\sec(\theta)$ |           |            |            |            |            |             |             |             |             |
| $\cot(\theta)$ |           |            |            |            |            |             |             |             |             |

|                |             |             |             |             |             |             |             |             |
|----------------|-------------|-------------|-------------|-------------|-------------|-------------|-------------|-------------|
| $\theta$       | $210^\circ$ | $225^\circ$ | $240^\circ$ | $270^\circ$ | $300^\circ$ | $315^\circ$ | $330^\circ$ | $360^\circ$ |
| $\sin(\theta)$ |             |             |             |             |             |             |             |             |
| $\cos(\theta)$ |             |             |             |             |             |             |             |             |
| $\tan(\theta)$ |             |             |             |             |             |             |             |             |
| $\csc(\theta)$ |             |             |             |             |             |             |             |             |
| $\sec(\theta)$ |             |             |             |             |             |             |             |             |
| $\cot(\theta)$ |             |             |             |             |             |             |             |             |

(7) Let point  $P$  be  $(x, y)$  in rectangular coordinates and  $(r, \theta)$  in polar coordinates

(a) Given  $\tan(\theta) = \frac{7}{12}$  and  $P$  is in the third quadrant. What is  $\sin(\theta)$  and  $\cos(\theta)$ ?

(b) Given  $\cos(\theta) = -\frac{1}{\sqrt{12}}$  and  $P$  is in the second quadrant. What is  $\sin(\theta)$  and  $\tan(\theta)$ ?

(c) Given  $\sin(\theta) = -\frac{2}{5}$  and  $P$  is in the third quadrant. What is  $\cos(\theta)$  and  $\tan(\theta)$ ?

(d) Given  $\cot(\theta) = \frac{3}{4}$  and  $\sin(\theta) < 0$ , find  $\sin(\theta)$  and  $\cos(\theta)$ .

## 18. CIRCLES AND RADIAN MEASURE

- (1) The circumference of a circle is \_\_\_\_\_.
- (2) The formula for the circumference of a circle with radius  $r$  is \_\_\_\_\_. The formula for the area of a circle with radius  $r$  is \_\_\_\_\_.

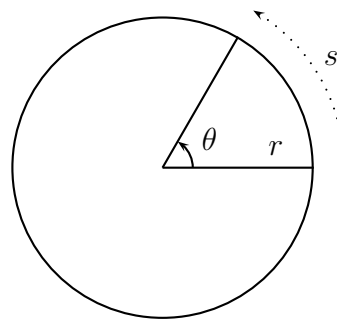
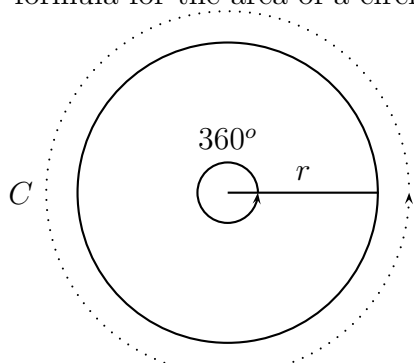

- (3) Let  $C$  denote the circumference of the circle, and  $s$  denote the arc length determined by angle  $\theta$  in degrees. Then  $\frac{C}{360} = \frac{s}{\theta}$ .
- (4) Let  $A$  denote the area of the circle, and  $A_s$  denote the area of the sector determined by angle  $\theta$  in degrees. Then  $\frac{A}{360} = \frac{A_s}{\theta}$ .
- (5) Find the arc length  $s$  and the area of the sector:
- $r = 20cm, \quad \theta = 40^\circ$ .

- $r = 30in, \quad \theta = 190^\circ$ .

- $r = 40ft, \quad \theta = 280^\circ$ .

- $r = 12m, \quad \theta = 130^\circ$ .

- $r = 30mm, \quad \theta = 35^\circ$ .

(6) Find the angle  $\theta$  in degrees:

- $r = 20cm, \quad s = 40cm$

- $r = 30in, \quad s = 100in$

- $r = 50ft, \quad s = 200ft$

- $r = 12ft, \quad s = 70ft$

- $r = 30mm, \quad s = 150mm$

- $r = 20cm, \quad s = 20cm$

- $r = 35in, \quad s = 35in$

- $r = 50cm, \quad s = 50cm$

- $r = 100cm, \quad s = 100cm$

A radian is the measure of an angle which determines an arc length equal to the radius.

1 radian = \_\_\_\_\_.

(7) Find the circumference  $C$ :

- $s = 10cm \quad \theta = 80^\circ$

- $s = 30ft \quad \theta = 60^\circ$

- $s = 80m \quad \theta = 130^\circ$

- $s = 40mm \quad \theta = 200^\circ$

- $s = 20cm \quad \theta = 300^\circ$



- (8) Recall 1 radian = \_\_\_\_\_. So  $\pi$  radians = \_\_\_\_\_. Express each angle in radians.

|             |             |             |             |
|-------------|-------------|-------------|-------------|
| $0^\circ$   | $30^\circ$  | $45^\circ$  | $60^\circ$  |
| $90^\circ$  | $120^\circ$ | $135^\circ$ | $150^\circ$ |
| $180^\circ$ | $210^\circ$ | $225^\circ$ | $240^\circ$ |
| $270^\circ$ | $300^\circ$ | $315^\circ$ | $330^\circ$ |
| $360^\circ$ | $390^\circ$ | $405^\circ$ | $420^\circ$ |

- (9) Express each angle in degrees:

|                 |                  |                  |
|-----------------|------------------|------------------|
| $\frac{\pi}{6}$ | $\frac{\pi}{2}$  | $-\frac{\pi}{2}$ |
| $\frac{\pi}{4}$ | $\frac{2\pi}{3}$ | $-5\pi$          |
| $\frac{\pi}{3}$ | $\frac{3\pi}{4}$ | $-1.35$          |

- (10) Let  $C$  denote the circumference of the circle, and  $s$  denote the arc length determined by angle  $\theta$  in radians. Then  $\frac{C}{2\pi} = \frac{s}{\theta}$ .
- (11) Let  $A$  denote the area of the circle, and  $A_s$  denote the area of the sector determined by angle  $\theta$  in radians. Then  $\frac{A}{2\pi} = \frac{A_s}{\theta}$ .
- (12) Find the arc length  $s$  and the area of the sector, where the angle is given in radians:
- $r = 20\text{cm}$ ,  $\theta = \frac{\pi}{3}$ .

- $r = 30\text{in}$ ,  $\theta = \frac{3\pi}{4}$ .

- $r = 40\text{ft}$ ,  $\theta = \frac{5\pi}{3}$ .

- $r = 12\text{m}$ ,  $\theta = \frac{11\pi}{6}$ .

- $r = 30mm, \quad \theta = 2.35.$

(13) Find the angle  $\theta$  in radians:

- $r = 20cm, \quad s = 40cm$

- $r = 30in, \quad s = 100in$

- $r = 50ft, \quad s = 200ft$

- $r = 12ft, \quad s = 70ft$

- $r = 30mm, \quad s = 150mm$

- $r = 20cm, \quad s = 20cm$

- $r = 35in, \quad s = 35in$

- $r = 50cm, \quad s = 50cm$

- $r = 100cm, \quad s = 100cm$

(14) Find the circumference  $C$ , where the angle is given in radians:

- $s = 10cm \quad \theta = \frac{\pi}{3}$

- $s = 30ft \quad \theta = \frac{3\pi}{4}$

- $s = 80m \quad \theta = \frac{5\pi}{3}$

- $s = 40mm \quad \theta = \frac{11\pi}{6}$

- $s = 20cm \quad \theta = 2.35$

(15) A bug is sitting on a phonograph record, 3 inches from the centre. The record is turning at the rate of 55 revolutions per minute. Find the distance travelled and the angle in radians through which the bug turned in 20 seconds.

## 19. THE UNIT CIRCLE AND THE TRIGONOMETRIC FUNCTIONS

The **unit circle** is the circle centered at  $(0, 0)$  and radius 1.

Equation for the unit circle is \_\_\_\_\_.

For a point  $P = (x, y)$  with polar coordinates  $(r, \theta)$ , recall

$$\sin(\theta) = \qquad \qquad \qquad \cos(\theta) = \qquad \qquad \qquad \tan(\theta) =$$

$$\csc(\theta) = \qquad \qquad \qquad \sec(\theta) = \qquad \qquad \qquad \cot(\theta) =$$

When the point  $P$  is on the unit circle with polar coordinates  $(r, \theta)$ , we have  $r = \underline{\hspace{2cm}}$ . So,

$$\sin(\theta) = \qquad \qquad \qquad \cos(\theta) = \qquad \qquad \qquad \tan(\theta) =$$

$$\csc(\theta) = \qquad \qquad \qquad \sec(\theta) = \qquad \qquad \qquad \cot(\theta) =$$

Find rectangular coordinates for all the end points of the radial segments shown on the unit circle below. Give the angles in both degree and radian form.

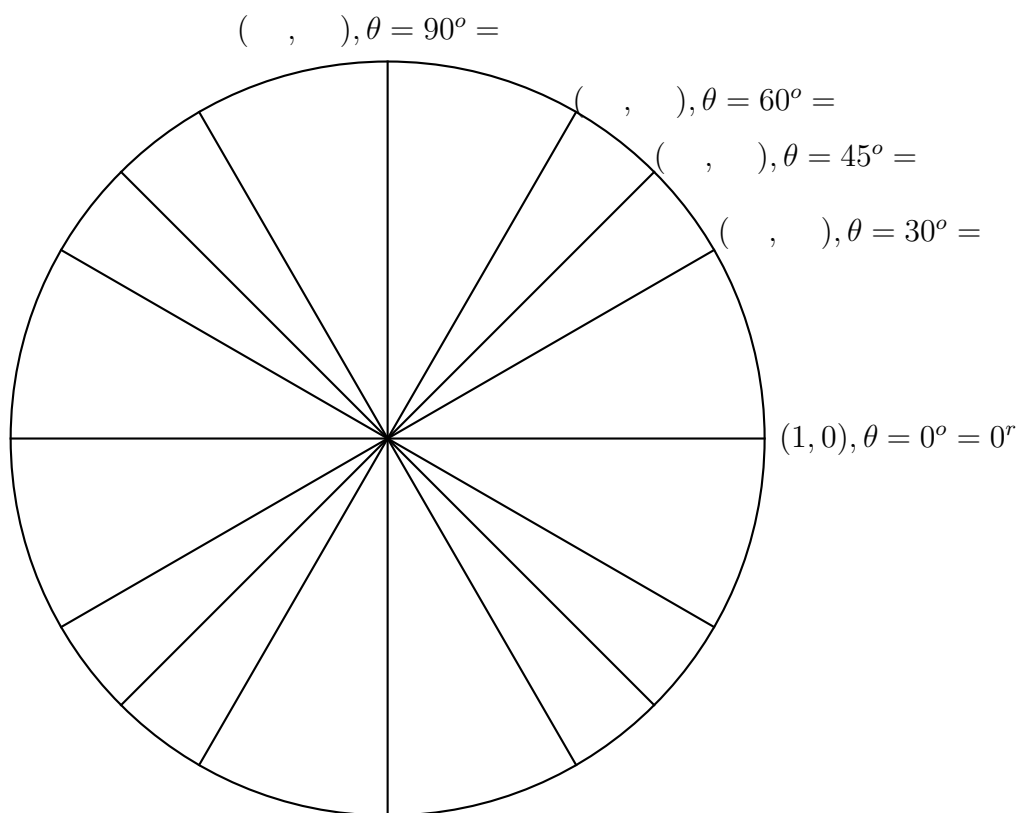

Here is a way of remembering the numbers you derived above:

$$0 < 1 < 2 < 3 < 4$$

*Take square root throughout*

*Divide throughout by 2*

How are these numbers to be used?

Use the unit circle to fill in the blanks:

| Function       | $0^\circ$ | $30^\circ$ | $45^\circ$ | $60^\circ$ | $90^\circ$ | $120^\circ$ | $135^\circ$ | $150^\circ$ | $180^\circ$ |
|----------------|-----------|------------|------------|------------|------------|-------------|-------------|-------------|-------------|
| $\sin(\theta)$ |           |            |            |            |            |             |             |             |             |
| $\cos(\theta)$ |           |            |            |            |            |             |             |             |             |
| $\tan(\theta)$ |           |            |            |            |            |             |             |             |             |
| $\csc(\theta)$ |           |            |            |            |            |             |             |             |             |
| $\sec(\theta)$ |           |            |            |            |            |             |             |             |             |
| $\cot(\theta)$ |           |            |            |            |            |             |             |             |             |

| Function       | $210^\circ$ | $225^\circ$ | $240^\circ$ | $270^\circ$ | $300^\circ$ | $315^\circ$ | $330^\circ$ | $360^\circ$ |
|----------------|-------------|-------------|-------------|-------------|-------------|-------------|-------------|-------------|
| $\sin(\theta)$ |             |             |             |             |             |             |             |             |
| $\cos(\theta)$ |             |             |             |             |             |             |             |             |
| $\tan(\theta)$ |             |             |             |             |             |             |             |             |
| $\csc(\theta)$ |             |             |             |             |             |             |             |             |
| $\sec(\theta)$ |             |             |             |             |             |             |             |             |
| $\cot(\theta)$ |             |             |             |             |             |             |             |             |

What happens when the angle is negative? Fill in the blanks.

| Function       | $0^\circ$ | $-30^\circ$ | $-45^\circ$ | $-60^\circ$ | $-90^\circ$ | $-120^\circ$ | $-135^\circ$ | $-150^\circ$ | $-180^\circ$ |
|----------------|-----------|-------------|-------------|-------------|-------------|--------------|--------------|--------------|--------------|
| $\sin(\theta)$ |           |             |             |             |             |              |              |              |              |
| $\cos(\theta)$ |           |             |             |             |             |              |              |              |              |
| $\tan(\theta)$ |           |             |             |             |             |              |              |              |              |
| $\csc(\theta)$ |           |             |             |             |             |              |              |              |              |
| $\sec(\theta)$ |           |             |             |             |             |              |              |              |              |
| $\cot(\theta)$ |           |             |             |             |             |              |              |              |              |

| Function       | $-210^\circ$ | $-225^\circ$ | $-240^\circ$ | $-270^\circ$ | $-300^\circ$ | $-315^\circ$ | $-330^\circ$ | $-360^\circ$ |
|----------------|--------------|--------------|--------------|--------------|--------------|--------------|--------------|--------------|
| $\sin(\theta)$ |              |              |              |              |              |              |              |              |
| $\cos(\theta)$ |              |              |              |              |              |              |              |              |
| $\tan(\theta)$ |              |              |              |              |              |              |              |              |
| $\csc(\theta)$ |              |              |              |              |              |              |              |              |
| $\sec(\theta)$ |              |              |              |              |              |              |              |              |
| $\cot(\theta)$ |              |              |              |              |              |              |              |              |

- $\sin^2(x) + \cos^2(x) =$
- $\sin(-x) =$
- $\cos(-x) =$

(1) Find all the angles  $\theta$ ,  $0^\circ \leq \theta < 360^\circ$  such that  $\cos(\theta) = -\frac{\sqrt{3}}{2}$ .

(2) Solve the equation  $\sin(x) = \frac{\sqrt{2}}{2}$ , where  $0 \leq x < 2\pi$  radians.

(3) Solve the equation  $\tan(x) = -\frac{1}{\sqrt{3}}$ , where  $0 \leq x < 2\pi$  radians.

Graph (the variable  $x$  is measured in radians):

- $\sin(x)$  for  $0 \leq x \leq 2\pi$ .

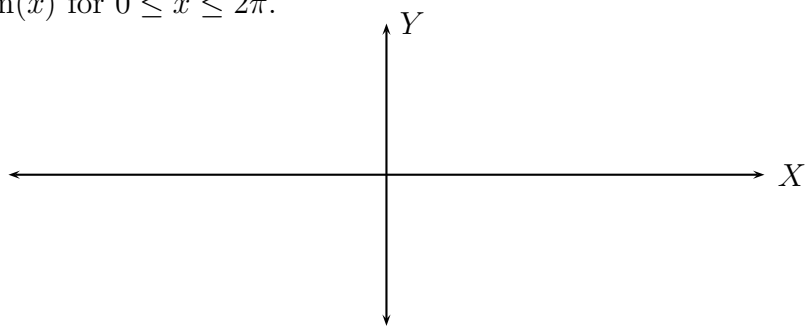

- $\sin(x)$  for every real number  $x$ .

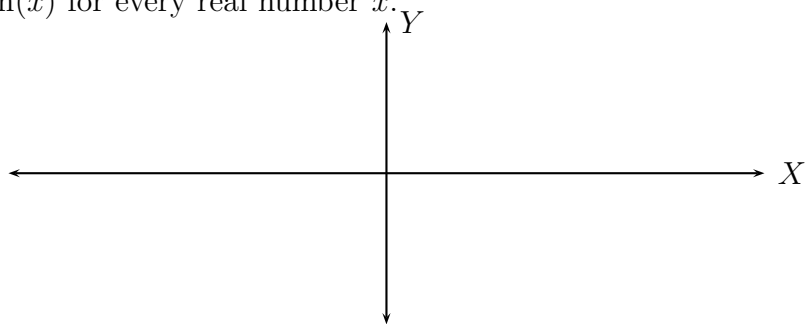

- $\cos(x)$  for  $0 \leq x \leq 2\pi$ .

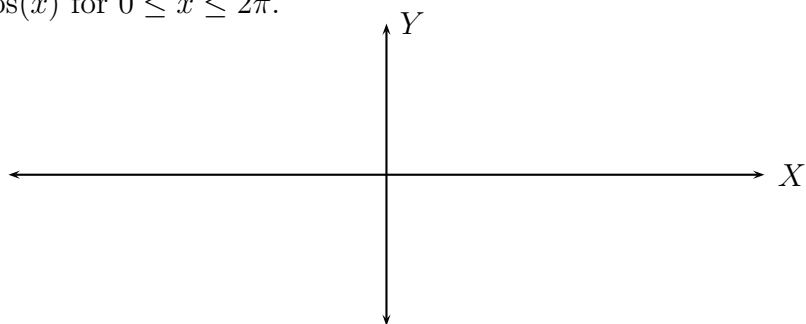

- $\cos(x)$  for every real number  $x$ .

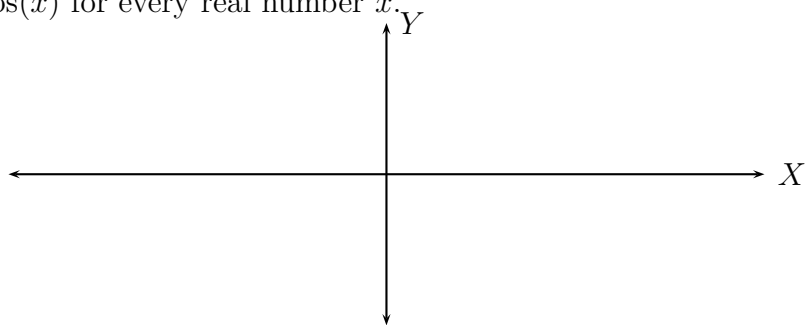

- $\tan(x)$  for  $0 \leq x \leq 2\pi$ .

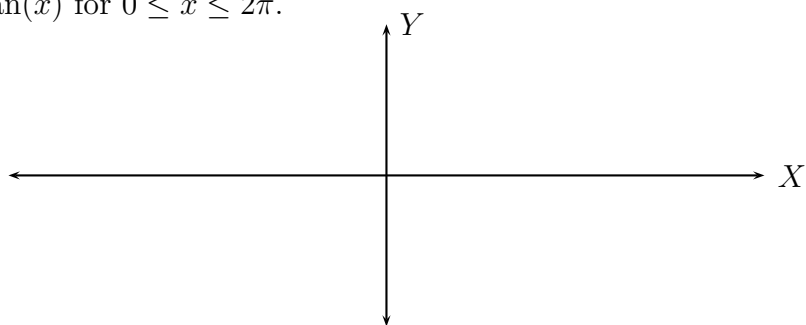

- $\tan(x)$  for every real number  $x$ .

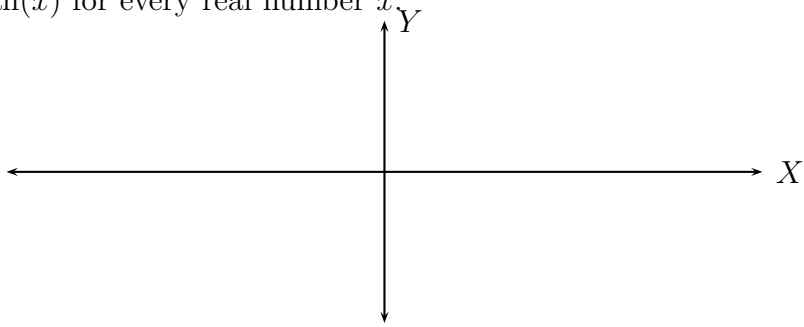

For the graph of  $y = \sin(x)$  or  $y = \cos(x)$

- What is the fundamental cycle?
- The graph is periodic with period \_\_\_\_\_.
- What is the sinusoidal axis of the graph?
- What is the amplitude?



## 20. GRAPHING TRIGONOMETRIC FUNCTIONS

- Graph the trigonometric function.
- What is its sinusoidal axis?
- What is its amplitude?

(1)  $y = 3 \sin(x)$ .

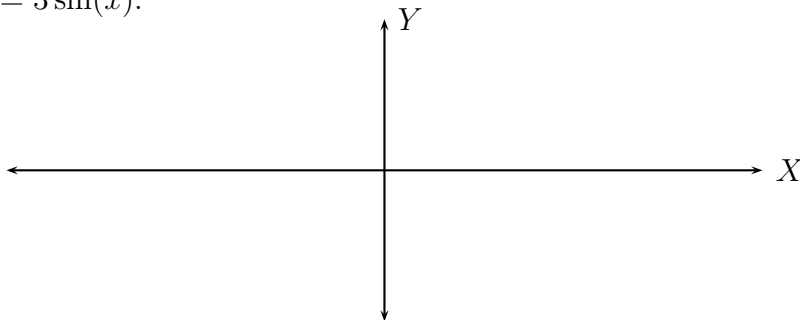

(2)  $y = -2 \cos(x)$ .

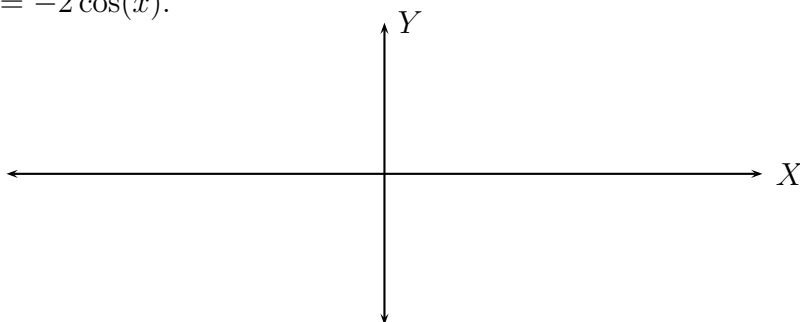

(3)  $y = -\frac{3}{2} \sin(x)$ .

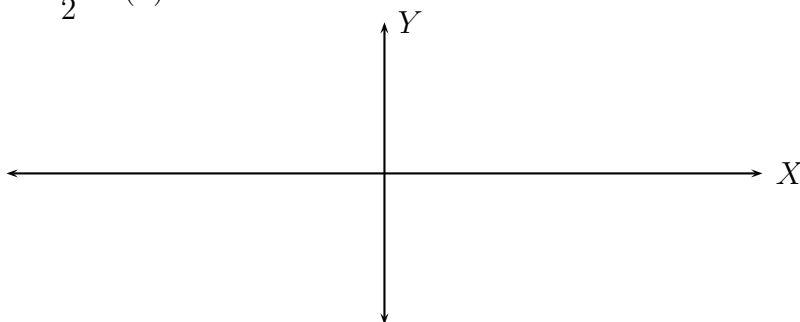

(4)  $y = \frac{1}{3} \cos(x)$ .

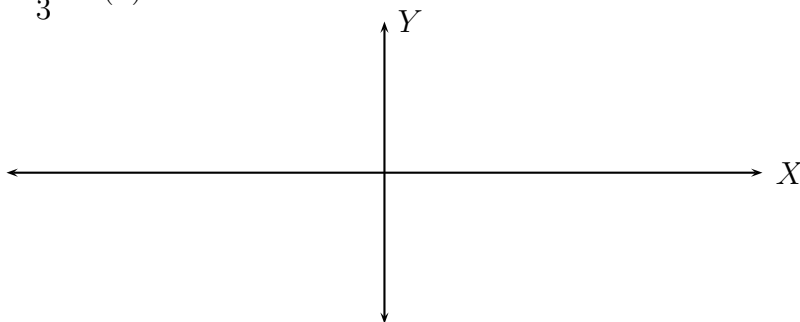

## 21. TRIGONOMETRIC IDENTITIES

Recall the basic identities:

- $\tan(x) = \frac{\sin(x)}{\cos(x)}$
- $\sec(x) = \frac{1}{\cos(x)}$
- $\csc(x) = \frac{1}{\sin(x)}$
- $\cot(x) = \frac{\cos(x)}{\sin(x)} = \frac{1}{\tan(x)}$
- $\sin^2(x) + \cos^2(x) = 1$
- $\sin(-x) = -\sin(x)$
- $\cos(-x) = \cos(x)$

Using these basic identities prove the following identities:

$$(1) \tan(x) \csc(x) \cos(x) = 1$$

$$(2) \frac{\cos^2(x) - \sin^2(x)}{\sin(x) \cos(x)} = \cot(x) - \tan(x)$$

$$(3) \sec^2(x) - \tan^2(x) = 1$$

$$(4) \sin(x) + \cos(x) = \frac{\tan(x) + 1}{\sec(x)}$$

$$(5) \ln(\csc(x)) = -\ln(\sin(x))$$

$$(6) \frac{\sec^4(x) - 1}{\tan^2 x} = 2 + \tan^2(x)$$

To master this topic answer as many problems as you can from your textbook on this topic.

## 22. PRACTICE PROBLEMS. MATH 06.

(1) Find the restricted values of:

(a)  $\frac{(x-3)(x+6)}{x(x+1)(x+2)}$

(b)  $\frac{y}{y^2-9} + \frac{7}{y} = \frac{3y+2}{y+3}$

(2) Add:

(a)  $\frac{y^2}{2y+8} + \frac{2y-4}{2y+8}$

(b)  $\frac{-1}{x-2} + \frac{2}{x}$

(c)  $\sqrt{75} + 4\sqrt{12} + 2\sqrt{48}$

(d)  $\frac{3}{x} + \frac{8}{x-4}$

(e)  $\frac{y^2}{2y+8} + \frac{3y-4}{2y+8}$

(3) Subtract:

(a)  $\frac{3x}{3x-2} - \frac{2x}{2x+1}$

(b)  $\frac{5x-4}{x} - \frac{2x+1}{8x+5}$

(c)  $\frac{x}{x+6} - \frac{x}{x^2-36}$

(d)  $5\sqrt{12} - \sqrt{75} - 2\sqrt{48}$

(e)  $4\sqrt{8} - 5\sqrt{50}$

(f)  $\sqrt[3]{81} - \sqrt[3]{24}$

(g)  $4 - \frac{1}{x^2}$   
 $2 + \frac{1}{x}$

(4) Multiply:

(a)  $(\sqrt{2} - \sqrt{6})(\sqrt{8} + 3\sqrt{3})$

(b)  $\frac{a^2 + a - 6}{a^2 + a} \cdot \frac{a^2 + 2a + 1}{a^3 - 4a}$

(c)  $(\sqrt{3} - 1)(\sqrt{6} + 3)$

(d)  $2\sqrt{5}(3\sqrt{2} - 4\sqrt{5})$

(e) (Complex numbers)  $(5 - 2i)(3 + i)$

(f) (Complex numbers)  $i^{17}$

(g)  $\frac{7w^2 - 14w}{w^2 + 3w - 10} \cdot \frac{w + 5}{21w}$

(5) Divide:

(a)  $\frac{a^2 - 9}{2a^2 - 6a} \div \frac{2a^2 + 5a - 3}{4a^2 - 1}$

(b)  $\frac{6x^3}{7y^4} \div \frac{36x^7}{49y^4}$

(c)  $\frac{1}{x} + \frac{2}{x+1}$

(c)  $\frac{3}{x^2}$

(d) (Complex numbers)  $\frac{3 - 2i}{1 + i}$

- (e) (Complex numbers)  $\frac{3 + 4i}{2 - 5i}$   
 (f) (Complex numbers)  $\frac{1 - i}{2 + 3i}$   
 (g) (Complex numbers)  $\frac{3 - i}{1 + i}$   
 (h) (Complex numbers)  $\frac{1}{i - 1}$   
 (i) (Complex numbers)  $\frac{1 - 2i}{3 + 5i}$

(6) Simplify:

- (a)  $\frac{1 + \frac{3}{a} - \frac{4}{a^2}}{1 + \frac{2}{a} - \frac{3}{a^2}}$   
 (b)  $\frac{a^3 - a}{6a - 6}$   
 (c)  $\sqrt{\frac{12}{2}}$   
 (d)  $\sqrt[3]{24}$   
 (e)  $\sqrt{50}$   
 (f)  $\sqrt{96}$   
 (g)  $\sqrt[3]{81}$   
 (h)  $\sqrt[4]{64}$   
 (i)  $\frac{2}{\sqrt{8}}$   
 (j)  $\frac{1}{\sqrt{4}}$   
 (k)  $\sqrt[3]{\frac{9}{8}}$   
 (l)  $\sqrt[4]{\frac{1}{16}}$   
 (m)  $\sqrt{\frac{2}{3}}$   
 (n)  $\sqrt[3]{\frac{1}{9}}$   
 (o)  $\sqrt{12x^5y^8}$   
 (p)  $\sqrt{180ab^7}$   
 (q)  $\sqrt[3]{81m^4n^8}$   
 (r)  $\left(\frac{12y^5z^3w^{-5}}{y^2z^{-3}w}\right)^{\frac{1}{3}}$   
 (s)  $\sqrt{\frac{3}{8}}$   
 (t)  $16^{-\frac{3}{4}}$   
 (u)  $\frac{1}{\sqrt[3]{9}}$   
 (v)  $\frac{1}{\sqrt{8}}$

$$\begin{aligned} \text{(w)} \quad & \frac{2 - \sqrt{3}}{1 + \sqrt{5}} \\ \text{(x)} \quad & \frac{4 - \sqrt{8}}{-1 + \sqrt{2}} \\ \text{(y)} \quad & \frac{4 - \frac{1}{x^2}}{2 + \frac{1}{x}} \\ \text{(z)} \quad & \sqrt[4]{32x^8y^{15}} \end{aligned}$$

(7) Simplify: (whenever relevant write the expression using positive exponents)

$$\begin{aligned} \text{(a)} \quad & \left( \frac{4a^{-3}b^3}{3b^{-5}} \right)^{\frac{1}{2}} \\ \text{(b)} \quad & \sqrt{98} - \sqrt{18} + \sqrt{8} \\ \text{(c)} \quad & \left( \frac{16x^9y^{13}}{x^{17}y} \right)^{\frac{1}{4}} \\ \text{(d)} \quad & \left( \frac{27x^{22}y^5}{xy^2} \right)^{\frac{1}{3}} \\ \text{(e)} \quad & \left( \frac{a^4b^6}{ab^{-3}} \right)^{-\frac{1}{3}} \\ \text{(f)} \quad & \sqrt{\frac{3}{8}} \\ \text{(g)} \quad & \frac{1}{2 + \sqrt{3}} \\ \text{(h)} \quad & \frac{3}{\sqrt{5} - 1} \\ \text{(i)} \quad & \frac{\sqrt{3}}{\sqrt{2} - 1} \\ \text{(j)} \quad & \frac{\sqrt{2} - \sqrt{3}}{5 + \sqrt{3}} \\ \text{(k)} \quad & \frac{x^2 - x - 12}{x^2 - 4x - 12} \\ \text{(l)} \quad & \frac{x^2 - 4x - 12}{x^2 + 3x + 2} \end{aligned}$$

(8) Solve

$$\begin{aligned} \text{(a)} \quad & \frac{1}{x-2} - \frac{2}{x+2} = \frac{2}{x^2-4} \\ \text{(b)} \quad & \frac{1}{t+4} - \frac{2}{t-3} = 1 \\ \text{(c)} \quad & \text{(By completing the square): } 2x^2 + 5x - 2 = 0 \\ \text{(d)} \quad & \text{(By completing the square): } t^2 + 6t - 3 = 0 \\ \text{(e)} \quad & \text{(By completing the square): } x^2 - 8x - 9 = 0 \\ \text{(f)} \quad & \text{(By completing the square): } y^2 + 3y - 1 = 0 \\ \text{(g)} \quad & \text{(By completing the square): } 3x^2 + 4x - 1 = 0 \\ \text{(h)} \quad & \text{(By completing the square): } 3x^2 + 2x + 5 = 0 \\ \text{(i)} \quad & \text{(By using the quadratic formula): } 3y^2 + 4y = 1 \\ \text{(j)} \quad & \text{(By using the quadratic formula): } (x-1)(2x+3) = -5 \\ \text{(k)} \quad & x^2 + 4x = 2 \end{aligned}$$

- (l)  $4x^2 - 12x + 9 = 0$
- (m)  $2y^2 - 5y + 2 = 0$
- (n)  $w^2 - 10w = 3$
- (o)  $\sqrt{x-4} + 4 = x$
- (p)  $\sqrt{6x+1} = 2x - 3$
- (q)  $x^2 - 6x + 5 = 0$
- (r)  $3x^2 - 27 = 0$
- (s)  $x^2 - 5x = 5$
- (t)  $x^2 - 5x = 0$
- (u)  $x^2 + 10x + 9 = 0$
- (v)  $6x^2 + x = 15$
- (w)  $3x^2 = 30 - 9x$
- (x)  $(2x - 3)(x - 1) = -1$
- (y)  $x^2 - x = 12$
- (z)  $2x^2 = x - 1$

(9) Solve:

- (a)  $\frac{2}{n-2} - \frac{n}{n+5} = \frac{10n+15}{n^2+3n-10}$
- (b)  $3x^2 + 2x = 1$
- (c)  $\sqrt{3x+1} - 2 = 1$
- (d)  $\sqrt{2x-1} = x - 8$
- (e)  $\sqrt[3]{x+6} = 2$
- (f)  $\sqrt{2c-1} = \sqrt{3c+1} - 1$
- (g)  $\sqrt{5y+6} - \sqrt{3y+4} = 2$
- (h) the triangle  $ABC$  if  $m\angle A = 42^\circ$ ,  $m\angle C = 90^\circ$ , and  $b = 14$ .
- (i) the triangle  $ABC$  if  $m\angle A = 34^\circ$ ,  $m\angle C = 90^\circ$ , and  $c = 12$ .
- (j) the triangle  $ABC$  if  $m\angle B = 28^\circ$ ,  $m\angle C = 90^\circ$ , and  $a = 8$ .
- (k) the triangle  $ABC$  if  $m\angle C = 90^\circ$ , and  $a = 3$ ,  $c = 5$ .
- (l) the triangle  $ABC$  if  $m\angle C = 90^\circ$ , and  $a = 1$ ,  $b = 4$ .
- (m) the triangle  $ABC$  if  $m\angle C = 90^\circ$ , and  $b = 2$ ,  $c = 7$ .
- (n)  $3^{2x} = 9$
- (o)  $2^x = 16$
- (p)  $9^x = 27$
- (q)  $\log_3 x = -1$
- (r)  $\log_3 x = \frac{1}{2}$
- (s)  $\log_2 \left( \frac{1}{16} \right) = x$
- (t)  $\log_5 x = -3$

(10) Convert from degrees to radians or from radians to degrees:

- (a)  $135^\circ$
- (b)  $\frac{2\pi}{3}$
- (c)  $\frac{5\pi}{8}$

- (d)  $75^\circ$
- (11) Find the exact value of
- $\cos(150^\circ)$
  - $\sin(225^\circ)$
  - $\tan\left(\frac{7\pi}{6}\right)$
  - $\csc\left(\frac{2\pi}{3}\right)$
  - $\cos(60^\circ) - \sin(60^\circ)$
  - $\sec(45^\circ) \cdot \tan(30^\circ)$
  - $\cos\left(\frac{\pi}{6}\right) \cdot \tan\left(\frac{\pi}{3}\right)$
- (12) Verify the identity:
- $\csc x - \sin x = \cos x \cot x$
  - $\cos \theta \csc \theta = \cot \theta$
  - $\tan u + 1 = (\sec u)(\sin u + \cos u)$
  - $1 - \sin y = \frac{\cos^2 y}{1 + \sin y}$
  - $\tan \alpha = \frac{\cos \alpha \sec \alpha}{\cot \alpha}$
  - $\sec^2 u - \tan^2 u = 1$
- (13) Given point  $P$  determined by angle of measure  $\theta$  find all the trigonometric ratios for  $\theta$ :
- $P(1, 5)$
  - $P(-2, -4)$
  - $P(-2, 6)$
  - $P(6, -2)$
  - $P(-1, 4)$
  - $P(0, 4)$
- (14) Sketch the graph
- $y = -2 \cos x$  for  $0 \leq x \leq 4\pi$ .
  - $y = 2 \sin x$  for  $-\pi \leq x \leq 3\pi$ .
  - $y = -3 \sin x$  for  $-\pi \leq x \leq 3\pi$ .
  - $y = 4 \cos x$  for  $-\pi \leq x \leq 3\pi$ .
  - $y = -4 \cos x$  for  $-\pi \leq x \leq 3\pi$ .
  - $y = x^2 - 4x + 3$ . Find the vertex and the  $x$ -intercepts.
  - $y = x^2 - 2x - 5$ . Find the vertex and the  $x$ -intercepts.
  - $y = x^2 - 2x$ . Find the vertex and the  $x$ -intercepts.
  - $y = 5^x$
  - $y = \log_3 x$
- (15) Given a right triangle  $ABC$  with  $m\angle C = 90^\circ$ , find all the trigonometric ratios for  $\angle A$  given:
- $a = 4, b = 7$
  - $a = 6, b = 8$
  - $b = 3, c = 10$
  - $a = 12, c = 13$
- (16) Find all the trigonometric ratios for an acute angle of measure  $\theta$  satisfying:

- (a)  $\cos \theta = \frac{2}{3}$
- (b)  $\sin \theta = \frac{1}{4}$
- (c)  $\tan \theta = \frac{7}{5}$
- (d)  $\csc \theta = 8$

(17) Find the measure in degrees and in radians of the angle determined by the point:

- (a)  $P(-3, 6)$
- (b)  $P(1, -5)$
- (c)  $P(2, 4)$
- (d)  $P(-1, -3)$

(18) Find all angles  $0 \leq \theta < 360$  satisfying:

- (a)  $\cos \theta = \frac{3}{4}$
- (b)  $\sin \theta = -\frac{2}{3}$
- (c)  $\tan \theta = -0.3$
- (d)  $\sec \theta = -4$
- (e)  $\sin \theta = -\frac{\sqrt{3}}{2}$
- (f)  $\tan \theta = -1$

(19) Find the arc length determined by the angle of measure  $\theta$  and radius  $r$ :

- (a)  $r = 3, \theta = \frac{2\pi}{3}$
- (b)  $r = 18, \theta = 100^\circ$
- (c)  $r = 12, \theta = 120^\circ$

(20) Word problems:

- (a) The length of a rectangle is one cm less than three times the width. The area is 5 square cm. Find the dimensions of the rectangle, rounded to the nearest tenth.
- (b) Working together, Isaac and Sonia can wash a car in 10 minutes. Isaac can wash the car alone in 30 minutes. How long does Sonia take to wash the car alone?
- (c) Working together, two roommates can paint their apartment in  $3\frac{1}{3}$  hours. If it takes one roommate twice the time to paint the room than it takes for the other roommate, how long does it take each of the two to paint the room working alone?
- (d) The length of a rectangle is 3 cm less than twice its width. The area is 35 square cm. Find the dimensions of the rectangle.
- (e) The angle of elevation of the top of a tree to a point 40 feet from the base of the tree is  $73^\circ$ . Find the height of the tree.
- (f) At a point which is 92 feet from a building, the angle of elevation of the top of the building is  $50^\circ$  and the angle of elevation to the top of a flagpole mounted on top of the building is  $58^\circ$ . How tall is the flagpole?